

DDX VALVE TRIMS PART NUMBER CONFIGURATION SELECTIONS IN BOLD ARE STANDARD OPTIONS

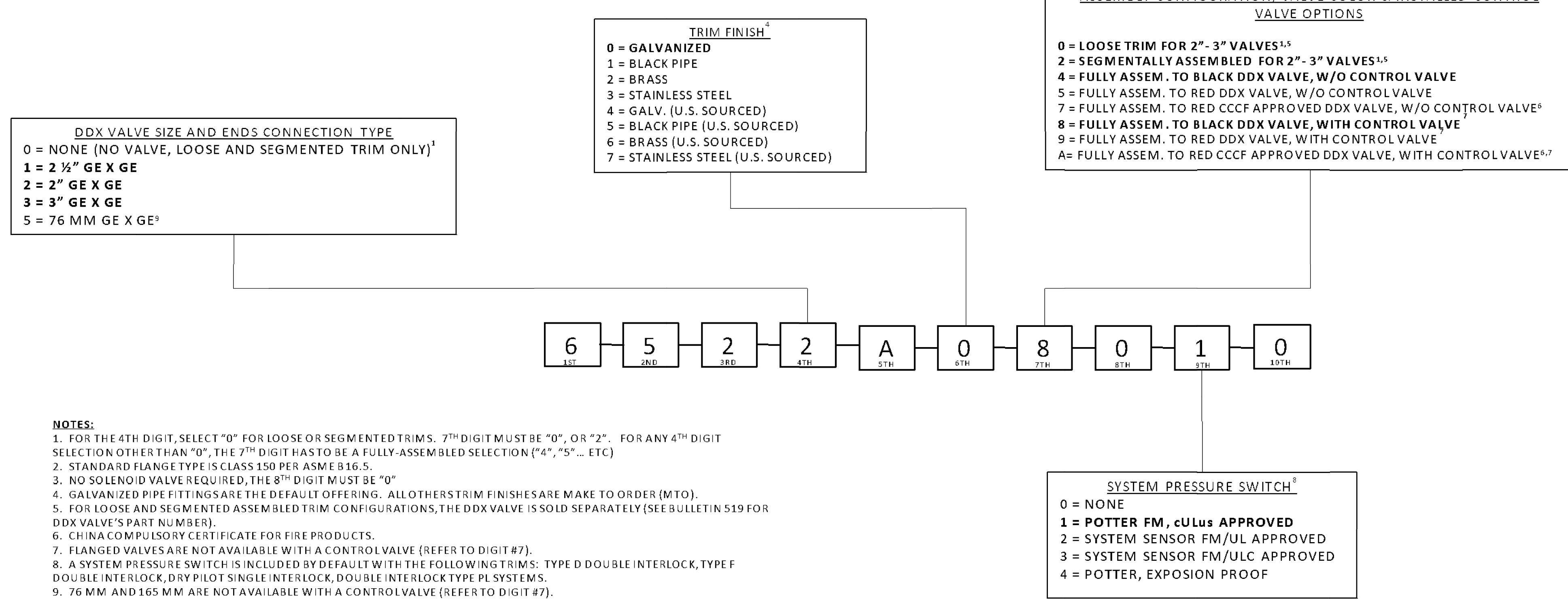

- NOTES:**
- FOR THE 4TH DIGIT, SELECT "0" FOR LOOSE OR SEGMENTED TRIMS. 7TH DIGIT MUST BE "0", OR "2". FOR ANY 4TH DIGIT SELECTION OTHER THAN "0", THE 7TH DIGIT HAS TO BE A FULLY-ASSEMBLED SELECTION ("4", "5"... ETC).
 - STANDARD FLANGE TYPE IS CLASS 150 PER ASME B16.5.
 - NO SOLENOID VALVE REQUIRED, THE 8TH DIGIT MUST BE "0".
 - GALVANIZED PIPE FITTINGS ARE THE DEFAULT OFFERING. ALL OTHER TRIM FINISHES ARE MAKE TO ORDER (MTO).
 - FOR LOOSE AND SEGMENTALLY ASSEMBLED TRIM CONFIGURATIONS, THE DDX VALVE IS SOLD SEPARATELY (SEE BULLETIN 519 FOR DDX VALVE'S PART NUMBER).
 - CHINA COMPRESSION CERTIFICATE FOR FIRE PRODUCTS.
 - FLANGED VALVES ARE NOT AVAILABLE WITH A CONTROL VALVE (REFER TO DIGIT #7).
 - A SYSTEM PRESSURE SWITCH IS INCLUDED BY DEFAULT WITH THE FOLLOWING TRIMS: TYPE D DOUBLE INTERLOCK, TYPE F DOUBLE INTERLOCK, DRYPILOT SINGLE INTERLOCK, DOUBLE INTERLOCK TYPE PL SYSTEMS.
 - 76 MM AND 165 MM ARE NOT AVAILABLE WITH A CONTROL VALVE (REFER TO DIGIT #7).

DDX VALVE PART NUMBER TABLE

DDX VALVE	VALVE PART NUMBER	DRAWING FILE NUMBER
2" DUCTILE IRON G/G BLACK	6103022000	6103030000
2" DUCTILE IRON G/G RED	6103022001	
2-1/2" DUCTILE IRON G/G BLACK	6103022500	
2-1/2" DUCTILE IRON G/G RED	6103022501	
3" DUCTILE IRON G/G BLACK	6103030000	
3" DUCTILE IRON G/G RED	6103030001	
76MM DUCTILE IRON G/G RED	6103027600	

MODEL DDX 2"-3" DELUGE S.I. DRY PILOT
 CA-188 P/N 89241150
 ASSEMBLY P/N 6520A00010 REV. G

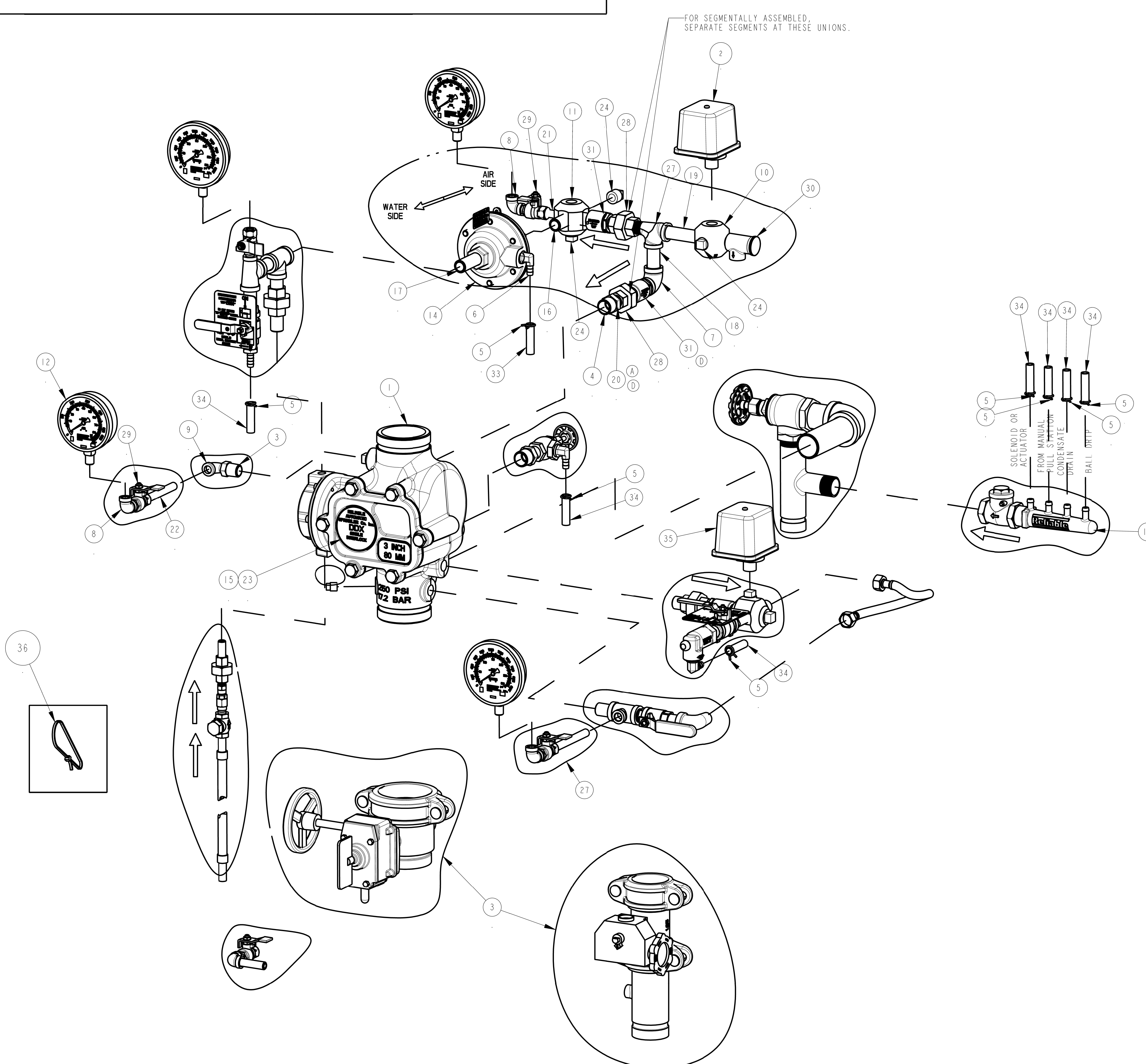

ITEM NO.	PART NO.	DESCRIPTION	QTY.
36	89141112	TIE, RETAINING	9
	6990012997	SWITCH, POTTER PRESSURE (PS10-EX)	(ULC, UL, FM)
	6990006382	SWITCH, POTTER PRESSURE (PS10-2)	(ULC, UL, FM)
35	6999992360	SWITCH, PRESSURE (EPS10-2)	(ULC)
	6999991212	SWITCH, PRESSURE (EPS10-2)	(UL/FM)
34	9686756	TUBING, PVC, 3/8" I.D. x 6 FT.	1
33	95516915	PERMA-LOK	NOT SHOWN
32	96816906	VALVE, CHECK, MALE 1/2", MALE 1/2"	2
31	98840228	VALVE, RELIEF, 1/2", 50 PSI	1
30	98840237	VALVE, BALL, 1/4" NPTF x 1/4" NPTM	2
29	98815204	UNION, ORING SEAL, GALV., 1/2"	2
28	96806654	TEE, GALV., 1/2-M x 1/2-F x 1/2-F	1
27	77000263	SUB-ASSEMBLY, TRIM, BASE, GALVANIZED PIPE	1
26	77000303	SUB-ASSEMBLY CONTROL VALVE	1
25	98604406	PIPE, PLUG, IRON, SQUARE HEAD, 1/2"	3
24	99080002	PAD-ADHESIVE, VALVE NAME PLATES	1
23	98543243	NIPPLE, 1/4X4, GALVANIZED STEEL	1
22	98543226	NIPPLE, 1/4X1-1/2, GALVANIZED STEEL	1
21	98543212	NIPPLE, 1/2XCLOSE, GALVANIZED STEEL	1
20	98543230	NIPPLE, 1/2X3, GALVANIZED STEEL	1
19	98543209	NIPPLE, 1/2X2, GALVANIZED STEEL	1
18	98543210	NIPPLE, 1/2X2-1/2, GALVANIZED STEEL	1
17	98543223	NIPPLE, 1/2X1-1/2, GALVANIZED STEEL	1
16	94616917	NAMEPLATE, SINGLE INTERLOCK	1
15	71030010	MODEL LP PILOT LINE ACTUATOR	1
14	91004299	MANIFOLD, DRAIN, BARBED, 6-3/16	1
13	98248000	GAUGE, AIR PRESSURE (0-80 PSI)	2
12	98751003	FITTING, MULTIPORT, 1/2x1/2x1/2x1/2x1/4	1
11	98751004	FITTING, MULTIPORT, 1/2x1/2x1/2x1/2x1/2	1
10	98174408	ELBOW, STREET, 1/4", GALV.	1
9	98174404	ELBOW, 1/4", MALL IRON, GALV.	2
8	98174401	ELBOW, 1/2", MALL IRON, GALV.	1
7	92056704	CONNECTOR, ELBOW, 3/8" ID TUBE x 1/2" NPT	1
6	95306255	CLAMP, HOSE, 1/2" CONSTANT TENSION, ZINC	8
5	98048022	BUSHING, REDUCER, 3/4x1/2, GALVANIZED	1
4	98048000	BUSHING, REDUCER, 1/2x1/4, GALVANIZED	1
3	77000303	SUBASSEMBLY, CONTROL VALVE, 3"	FULLY ASSEMBLED WITH CONTROL VALVE ONLY
	77000302	SUBASSEMBLY, CONTROL VALVE, 2-1/2"	
	77000301	SUBASSEMBLY, CONTROL VALVE, 2"	
2	6990003756	SWITCH, PRESSURE (PS40-EX)	(ULC, UL, FM)
	6990019313	SWITCH, PRESSURE (PS25-2)	(ULC, UL, FM)
	6999992361	SWITCH, PRESSURE (EPS40-2)	(ULC)
	6999991340	SWITCH, PRESSURE (EPS40-2)	(UL/FM)
1	SEE DDX VALVE P/N TABLE		

REVISIONS			
LTR	DESCRIPTION	DATE	DRAWN BY
	SEE PAGE 1		

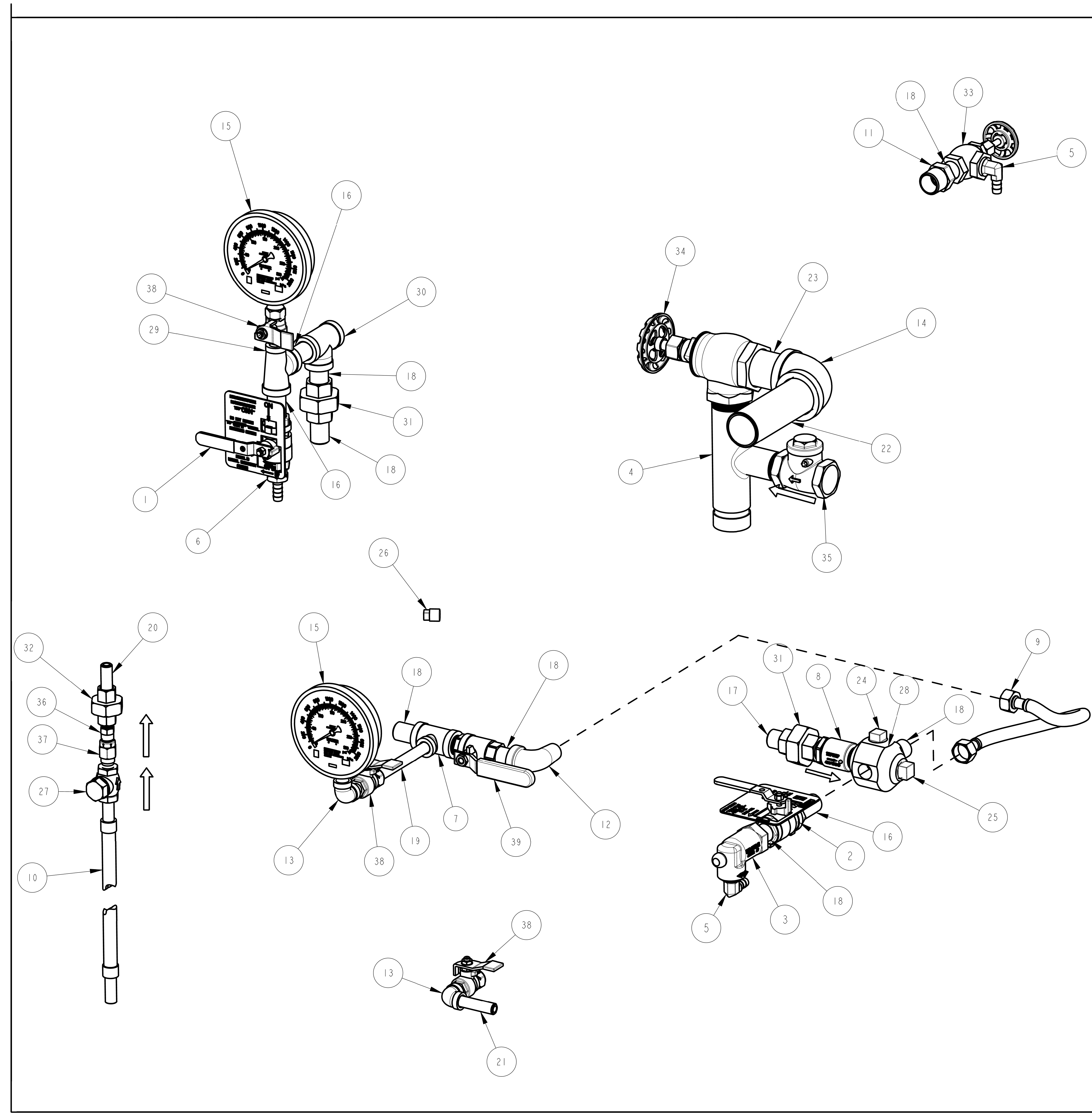

MODEL DDX 2"-3" BASIC TRIMS
 CA-323
 SUBASSEMBLY P/N 77000263 REV. E

ITEM NO.	PART NO.	DESCRIPTION	REMARKS	QTY.
40	95516915	THREAD, SEALANT	NOT SHOWN	A/R
39	9884011A	VALVE, BALL, 1/2 NPTF X 1/2 NPTM		1
38	98840237	VALVE, BALL, 1/4" NPTF x 1/4" NPTM		3
37	98840188	VALVE, CHECK, 1/4" NPTM x 1/4" NPTF		1
36	98840147	CHECK VALVE, 1/4, NPT, POPPET TYPE INLINE		1
35	98840145	SWING CHECK VALVE, 1" NPT		1
34	98840106	VALVE, ANGLE, 1 1/4		1
33	98840103	VALVE, ANGLE, 1/2"		1
32	98815201	UNION, 1/4, IRON, G. J., GALV.		1
31	98815200	UNION, 1/2, IRON, G. J., GALV.		2
30	98761651	TEE, 1/2X1/2X1/2, GALVANIZED		1
29	98761649	TEE, 1/2X1/4X1/2, GALVANIZED		1
28	98751005	FITTING, MULTIPOINT, 3/4X1/2X1/2X1/2X1/2		1
27	98727607	STRAINER, 1/4"		1
26	98614403	PIPE, PLUG, IRON, SQUARE HEAD, 1/4		1
25	98614401	PIPE, PLUG, IRON, SQUARE HEAD, 3/4		1
24	98604406	PIPE, PLUG, IRON, SQUARE HEAD, 1/2		1
23	98543285	NIPPLE, 1-1/4XCLOSE, GALVANIZED STEEL		1
22	98543284	NIPPLE, 1-1/4X5, GALVANIZED STEEL		1
21	98543244	NIPPLE, 1/4X2, GALVANIZED STEEL		1
20	98543226	NIPPLE, 1/4X1-1/2, GALVANIZED STEEL		1
19	98543224	NIPPLE, 1/4X4-1/2, GALVANIZED STEEL		1
18	98543223	NIPPLE, 1/2X1-1/2, GALVANIZED STEEL		7
17	98543212	NIPPLE, 1/2XCLOSE, GALVANIZED STEEL		1
16	98543209	NIPPLE, 1/2X2, GALVANIZED STEEL		3
15	98248001	GAUGE, WATER PRESSURE (0-300 PSI)		2
14	98174414	ELBOW, 1-1/4", MALL IRON, GALV.		1
13	98174404	ELBOW, 1/4", MALL IRON, GALV.		2
12	98174400	ELBOW, STREET, 1/2", GALV.		1
11	98048022	BUSHING, REDUCER, 3/4X1/2, GALVANIZED		1
10	96920944	HOSE, FLEXIBLE, STAINLESS STEEL, 1/4 NPT X 18 LONG		1
9	96920912	FLEX LINE, 12		1
8	96816906	VALVE, CHECK, MALE 1/2, MALE 1/2		1
7	96606607	TEE, 1/2X1/2X1/4, GALVANIZED		1
6	92056810	CONNECTOR, 3/8" ID TUBE x 1/2" NPT		1
5	92056704	CONNECTOR, ELBOW, 3/8" ID TUBE x 1/2" NPT		2
4	9101423C	MANIFOLD, 1-1/4 X 1-1/4 X 1, GRV/THD/THD		1
3	78653800	ASSEMBLY, BALL DRIP, 1/2"		1
2	78653004	ASSEMBLY, VALVE CAUTION STATION, 1/2"		1
1	78653000	ASSEMBLY, MANUAL EMERGENCY STATION		1

BILL OF MATERIALS

MTL N/A	THE RELIABLE AUTOMATIC SPRINKLER CO., INC. LIBERTY, S.C.			
FINISH	PART NO. 77000263	DWG. SIZE: D		
DO NOT SCALE DRAWING REMOVE BURRS, BREAK SHARP EDGES TOLERANCE UNLESS OTHERWISE SPECIFIED: ANGLE ± 1/2 63 MACH. FINISH CONC. TIR SQUARENESS - PARALLELISM	PART: SUB-ASSEMBLY, TRIM, BASE, GALVANIZED PIPE			
	PRODUCT: DDX 2"-3"			
	FILE NO. 77000263	ENG: JJ	DRW BY: PH	CKD:
		SCALE: 1:3	DATE: 04/25/13	SHEET 2 of 2

THIS DRAWING CONTAINS INFORMATION PROPRIETARY TO THE RELIABLE AUTOMATIC SPRINKLER CORP. IT MAY NOT BE REPRODUCED NOR MAY ANY INFORMATION HEREON BE DISCLOSED TO OTHERS WITHOUT THE SPECIFIC WRITTEN PERMISSION OF RELIABLE.

DDX VALVE PART NUMBER TABLE

DDX VALVE	VALVE PART NUMBER	DRAWING FILE NUMBER
4" DUCTILE IRON G/G BLACK	6103040026	6103040026
4" DUCTILE IRON G/G RED	6103040030	
4" DUCTILE IRON F/G CLASS 150 BLACK	6103040044	
4" DUCTILE IRON F/G CLASS 150 RED	6103040046	
4" DUCTILE IRON F/G PN16 RED	6103040048	6103040049
4" DUCTILE IRON F/F CLASS 150 BLACK	6103040045	
4" DUCTILE IRON F/F CLASS 150 RED	6103040047	
4" DUCTILE IRON F/F PN16 RED	6103040049	
6" DUCTILE IRON G/G BLACK	6103060024	6103060024
6" DUCTILE IRON G/G RED	6103060030	
6" DUCTILE IRON F/G CLASS 150 BLACK	6103060045	
6" DUCTILE IRON F/G CLASS 150 RED	6103060048	
6" DUCTILE IRON F/G PN16 RED	6103060049	
6" DUCTILE IRON F/F CLASS 150 BLACK	6103060046	
6" DUCTILE IRON F/F CLASS 150 RED	6103060047	
6" DUCTILE IRON F/F PN16 RED	6103060050	
165MM DUCTILE IRON G/G RED	6103060028	6103060024
165MM DUCTILE IRON F/G CLASS 150 RED	6103060051	
165MM DUCTILE IRON F/G PN16 RED	6103060052	
8" DUCTILE IRON G/G BLACK	6103080001	6103080001
8" DUCTILE IRON G/G RED	6103080003	
8" DUCTILE IRON F/F CLASS 150 BLACK	6103080016	
8" DUCTILE IRON F/F CLASS 150 RED	6103080018	
8" DUCTILE IRON F/F PN16 RED	6103080020	

DDX VALVE SIZE AND ENDS CONNECTION TYPE

0 = NONE (NO VALVE, LOOSE AND SEGMENTED TRIM ONLY)
 4 = 4" GEX GE
 6 = 6" GEX GE
 7 = 165 MM GEX GE
 8 = 8" GEX GE

DDX VALVE TRIMS PART NUMBER CONFIGURATION SELECTIONS IN **BOLD** ARE STANDARD OPTIONS

ASSEMBLY CONFIGURATION, VALVE COLOR & INSTALLED CONTROL VALVE OPTIONS

1 = LOOSE TRIM FOR 4"-8" VALVES^{1,4}
 3 = SEGMENTALLY ASSEMBLED FOR 4"-8" VALVES^{1,4}
 4 = FULLY ASSEM. TO BLACK DDX VALVE, W/O CONTROL VALVE
 5 = FULLY ASSEM. TO RED DDX VALVE, W/O CONTROL VALVE
 7 = FULLY ASSEM. TO RED CCCF APPROVED DDX VALVE, W/O CONTROL VALVE⁶
 8 = FULLY ASSEM. TO BLACK DDX VALVE, WITH CONTROL VALVE
 9 = FULLY ASSEM. TO RED DDX VALVE, WITH CONTROL VALVE
 A = FULLY ASSEM. TO RED CCCF APPROVED DDX VALVE, WITH CONTROL VALVE^{6,7}

TRIM FINISH⁴

0 = GALVANIZED
 1 = BLACK PIPE
 2 = BRASS
 3 = STAINLESS STEEL
 4 = GALV. (U.S. SOURCED)
 5 = BLACK PIPE (U.S. SOURCED)
 6 = BRASS (U.S. SOURCED)
 7 = STAINLESS STEEL (U.S. SOURCED)

SYSTEM PRESSURE SWITCH⁸

0 = NONE
 1 = POTTER FM, cULus APPROVED
 2 = SYSTEM SENSOR FM/UL APPROVED
 3 = SYSTEM SENSOR FM/ULC APPROVED
 4 = POTTER, EXPLOSION PROOF

NOTES:

- FOR THE 4TH DIGIT, SELECT "0" FOR LOOSE OR SEGMENTED TRIMS. 7TH DIGIT MUST BE "0", OR "2". FOR ANY 4TH DIGIT SELECTION OTHER THAN "0", THE 7TH HAS TO BE A FULLY ASSEMBLED SELECTION ("4", "5", "7", "8", "A").
- STANDARD FLANGE TYPE IS CLASS 150 PER ASME B16.5.
- SOLENOID VALVE REQUIRED, THE 8TH DIGIT CAN NOT BE "0".
- GALVANIZED PIPE FITTINGS ARE THE DEFAULT OFFERING. ALL OTHERS TRIM FINISHES ARE MAKE TO ORDER (MTO).
- FOR LOOSE AND SEGMENTED ASSEMBLED TRIM CONFIGURATIONS, THE DDX VALVE IS SOLD SEPARATELY (SEE BULLETIN 519 FOR DDX VALVE'S PART NUMBER).
- CHINA COMPULSIONARY CERTIFICATE FOR FIRE PRODUCTS.
- FLANGED VALVES ARE NOT AVAILABLE WITH A CONTROL VALVE (REFER TO DIGIT #7).
- A SYSTEM PRESSURE SWITCH IS INCLUDED BY DEFAULT WITH THE FOLLOWING TRIMS: TYPE D DOUBLE INTERLOCK, TYPE F DOUBLE INTERLOCK, DAY PILOT SINGLE INTERLOCK, DOUBLE INTERLOCK TYPE PL SYSTEMS.
- 76MM AND 165MM ARE NOT AVAILABLE WITH A CONTROL VALVE (REFER TO DIGIT #7).

MODEL DDX 4", 6" & 8" DELUGE SI. DRY PILOT
 CA-170 P/N 89241136
 ASSEMBLY P/N 6520A01010 REV. G

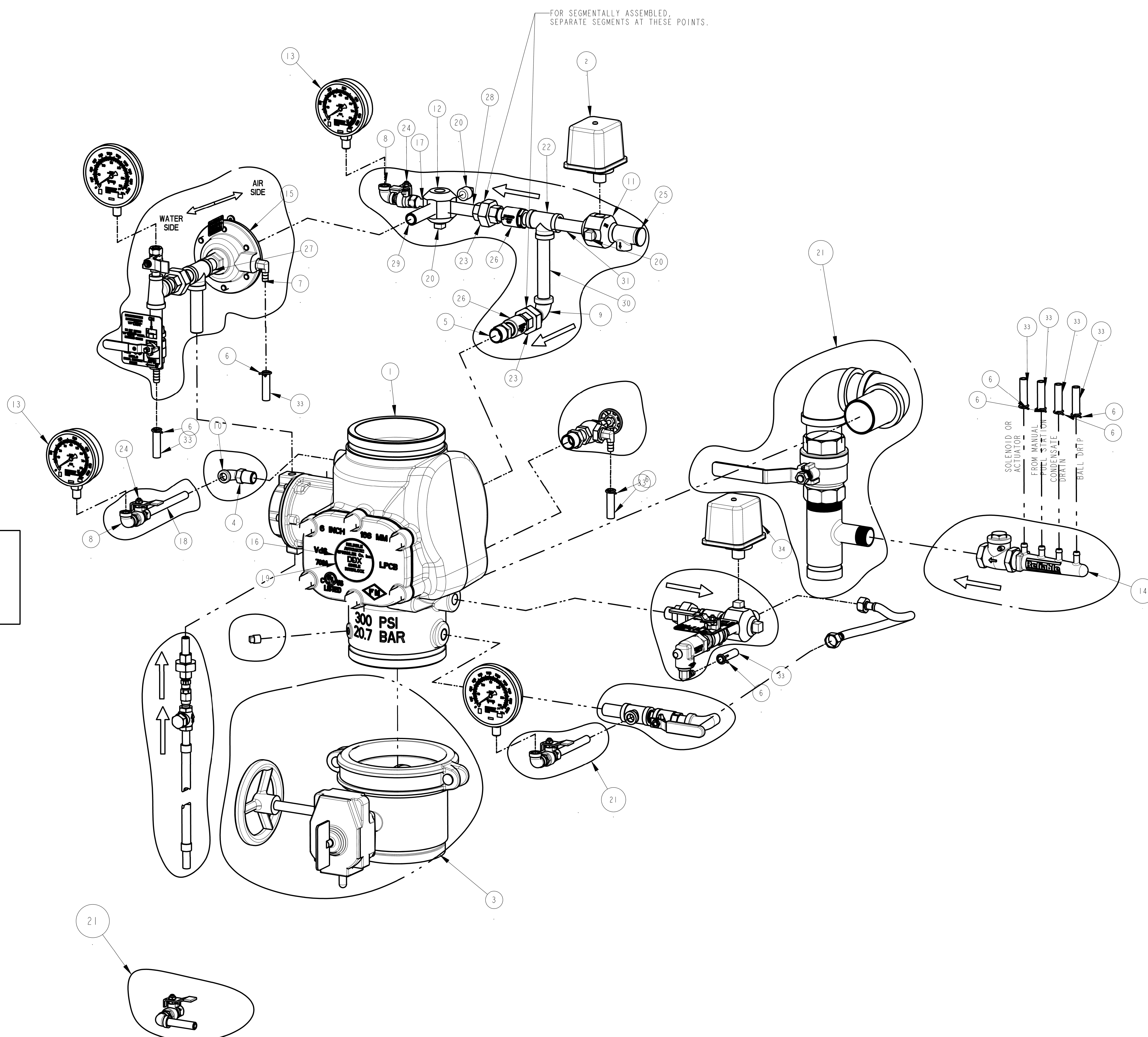

ITEM NO.	PART NO.	DESCRIPTION	REMARKS	QTY.
35	89141112	TIE, RETAINING	NOT SHOWN	9
	699006382	SWITCH, POTTER PRESSURE (PS10-2)	(ULC, UL, FM)	
	699001297	SWITCH, POTTER PRESSURE (PS10-EX)	(ULC, UL, FM)	1
34	699992360	SWITCH, PRESSURE (EPSA10-2)	(ULC)	
	6999991212	SWITCH, PRESSURE (EPS10-2)	(UL/FM)	
33	9668756	TUBING, PVC, 3/8" I.D. X 6 FT.	NOT SHOWN	1
32	95516915	PERMA-LOK	NOT SHOWN	A/R
	98543237	NIPPLE, 1/2X8, GALVANIZED STEEL	8" VERSION	1
31	98543230	NIPPLE, 1/2X3, GALVANIZED STEEL	4"-6" VERSIONS	
	98543223	NIPPLE, 1/2X1-1/2, GALVANIZED STEEL	8" VERSION	1
30	98543219	NIPPLE, 1/2X5, GALVANIZED STEEL	4"-6" VERSIONS	
	98543210	NIPPLE, 1/2X2-1/2, GALVANIZED STEEL	6"-8" VERSIONS	1
29	98543230	NIPPLE, 1/2X3, GALVANIZED STEEL	4" VERSIONS	
	98543216	NIPPLE, 1/2X2-1/2, GALVANIZED STEEL	8" VERSION	1
28	98543210	NIPPLE, 1/2X2-1/2, GALVANIZED STEEL	4"-6" VERSIONS	
	98543210	NIPPLE, 1/2X2-1/2, GALVANIZED STEEL	4"-6" VERSIONS	1
27	98543210	NIPPLE, 1/2X2-1/2, GALVANIZED STEEL	4"-6" VERSIONS	1
26	98816906	VALVE, CHECK, MALE 1/2, MALE 1/2		2
25	98840228	VALVE, RELIEF, 1/2", 50 PSI		2
24	98840237	VALVE, BALL, 1/4" NPTF x 1/4" NPTM		2
23	98815204	UNION, O-RING SEAL, GALV., 1/2		2
22	98761651	TEE, 1/2X1/2X1/2, GALVANIZED		1
21	77000266	SUB-ASSEMBLY, TRIM, BASE, GALVANIZED PIPE		1
20	98604406	PIPE, PLUG, IRON, SQUARE HEAD, 1/2		3
19	99080002	PAD-ADHESIVE, VALVE NAME PLATES		1
18	98543217	NIPPLE, 1/4X6, GALVANIZED STEEL		1
17	98543226	NIPPLE, 1/4X1-1/2, GALVANIZED STEEL		1
16	94616917	NAMEPLATE, SINGLE INTERLOCK		1
15	71030010	MODEL LP PILOT LINE ACTUATOR		1
14	91004299	MANIFOLD, DRAIN, BARBED, 6-3/16		1
13	98248000	GAUGE, AIR PRESSURE (0-80 PSI)		2
12	98751003	FITTING, MULTIPORT, 1/2x1/2x1/2x1/2x1/2x1/4		1
11	98751004	FITTING, MULTIPORT, 1/2x1/2x1/2x1/2x1/2		1
10	98174408	ELBOW, STREET, 1/4", GALV.		1
9	98174400	ELBOW, STREET, 1/2", GALV.		1
8	98174404	ELBOW, 1/4", MALL IRON, GALV.		2
7	92056704	CONNECTOR, ELBOW, 3/8" ID TUBE x 1/2" NPT		1
6	95306255	CLAMP, HOSE, 1/2" CONSTANT TENSION, ZINC		8
5	98048022	BUSHING, REDUCER, 3/4X1/2, GALVANIZED		1
4	98048000	BUSHING, REDUCER, 1/2X1/4, GALVANIZED		1
	77000308	SUBASSEMBLY, CONTROL VALVE, 8"	FULLY ASSEMBLED WITH CONTROL VALVE ONLY	1
3	77000306	SUBASSEMBLY, CONTROL VALVE, 6"		1
	77000304	SUBASSEMBLY, CONTROL VALVE, 4"		1
	6990003756	PRESSURE SWITCH, PS40-EX	(ULC, UL, FM)	
	6990019313	PRESSURE SWITCH, PS25-2	(ULC, UL, FM)	
2	699992361	PRESSURE SWITCH, EPSA40-2	(ULC)	1
	6999991340	PRESSURE SWITCH, EPS40-2	(UL/FM)	
1	SEE DDX VALVE P/N TABLE			1

MTL
 N/A
 FINISH
 DO NOT SCALE DRAWING
 REMOVE BURRS, BREAK SHARP EDGES
 TOLERANCE UNLESS OTHERWISE SPECIFIED
 ANGLE = 1/2° ± 0.5°
 MACH FINISH
 CONC. TIR
 SQUARENESS - PARALLELISM

THE RELIABLE AUTOMATIC SPRINKLER CO., INC.
 LIBERTY, SC.
 PART NO. VARIOUS
 PART: ASSEMBLY, TRIM, DRY PILOT, SINGLE INTERLOCK
 PRODUCT: DDX, 4", 6", 8"
 FILE NO. 6520A01010
 ENG. JJ
 SCALE: 1:4
 DRAW BY: PH
 DATE: 12/04/17
 CKD.: 3
 SHEET 26/3

THIS DRAWING CONTAINS INFORMATION PROPRIETARY TO THE RELIABLE AUTOMATIC SPRINKLER CORP. IT MAY NOT BE REPRODUCED NOR MAY ANY INFORMATION HEREON BE DISCLOSED TO OTHERS WITHOUT THE SPECIFIC WRITTEN PERMISSION OF RELIABLE.

REVISIONS			
LTR	DESCRIPTION	DATE	DRAWN BY
	SEE PAGE 1		

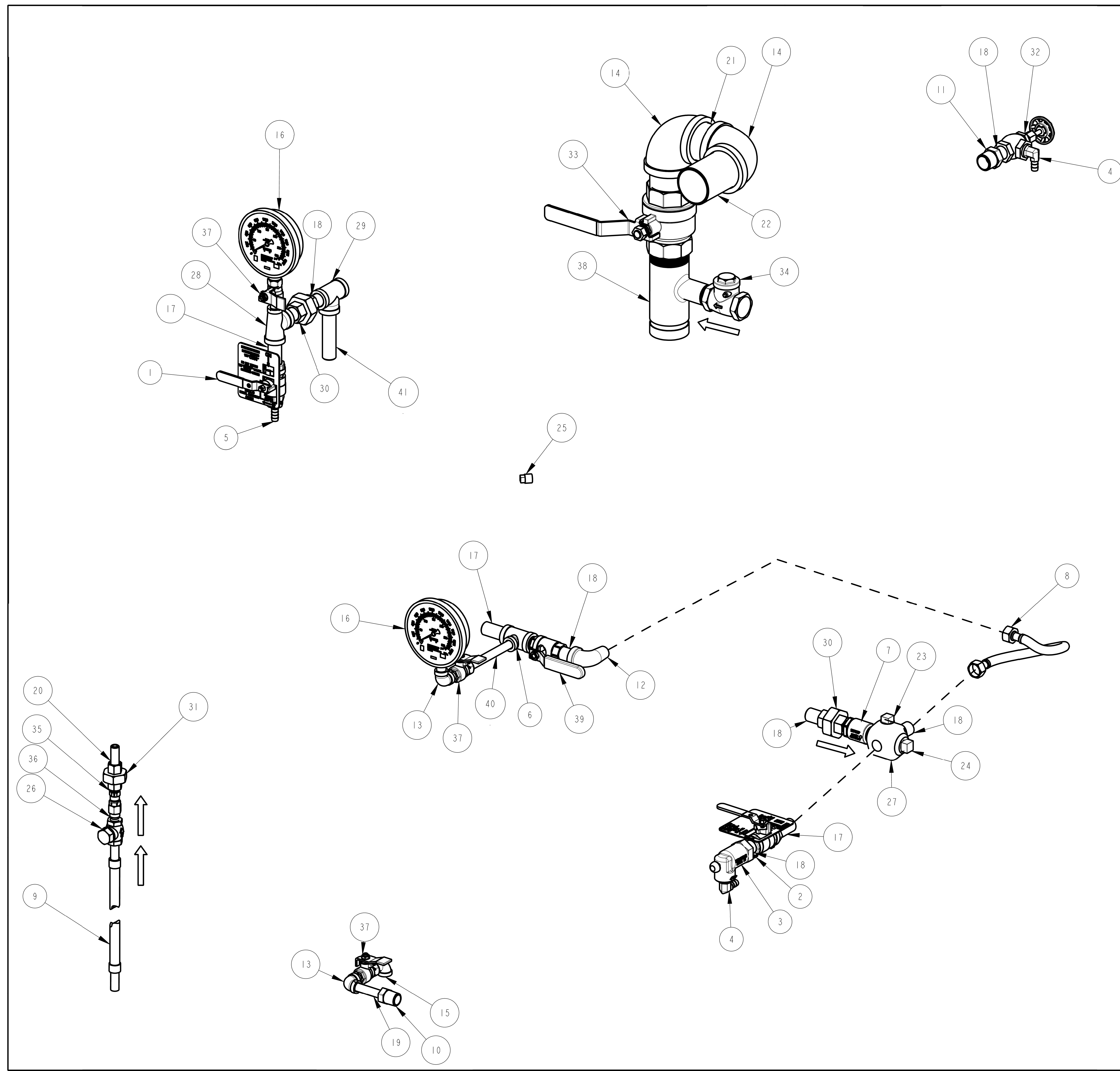

MODEL DDX 4", 6", 8" BASIC TRIMS
CA-322
SUBASSEMBLY P/N 77000266 REV. K

ITEM NO.	PART NO.	DESCRIPTION	REMARKS	QTY.
42	95516915	PERMA-LOK	NOT SHOWN	A/R
41	98543216	NIPPLE, STEEL, GALV., 1/2" X 3-1/2"	4" & 6" VERSIONS	1
	98543205	NIPPLE, STEEL, GALV., 1/2" X 9"	8" VERSION	1
	98543224	NIPPLE, STEEL, GALV., 1/4" X 4-1/2"	4" & 6" VERSIONS	1
40	98543217	NIPPLE, STEEL, GALV., 1/4" X 6"	8" VERSION	1
39	9884011A	VALVE, BALL, 1/2 NPTF x 1/2 NPTM		1
38	9101423B	MANIFOLD, 2 X 2 X 1, GRV/THD/THD		1
37	98840237	VALVE, BALL, 1/4" NPTF x 1/4" NPTM		3
36	98840188	VALVE, CHECK, 1/4" NPTM x 1/4" NPTF		1
35	98840147	CHECK VALVE, 1/4, NPT, POPPET TYPE INLINE		1
34	98840145	SWING CHECK VALVE, 1" NPT		1
33	98840136	VALVE, BALL, 2"		1
32	98840103	VALVE, ANGLE, 1/2"		1
31	98815201	UNION, 1/4, IRON, G. J., GALV.		1
30	98815200	UNION, 1/2, IRON, G. J., GALV.		2
29	98761651	TEE, 1/2X1/2X1/2, GALVANIZED		1
28	98761649	TEE, 1/2X1/4X1/2, GALVANIZED		1
27	98751005	FITTING, MULTIPORT, 3/4x1/2x1/2x1/2x1/2		1
26	98727607	STRAINER, 1/4"		1
25	98614403	PIPE, PLUG, IRON, SQUARE HEAD, 1/4		1
24	98614401	PIPE, PLUG, IRON, SQUARE HEAD, 3/4		1
23	98604406	PIPE, PLUG, IRON, SQUARE HEAD, 1/2		1
22	98543262	NIPPLE, 2X3-1/2, GALVANIZED STEEL		1
21	98543238	NIPPLE, 2XCLOSE, GALVANIZED STEEL		2
20	98543226	NIPPLE, 1/4X1-1/2, GALVANIZED STEEL		1
19	98543225	NIPPLE, 1/4X2-1/2, GALVANIZED STEEL		1
18	98543223	NIPPLE, 1/2X1-1/2, GALVANIZED STEEL		7
17	98543209	NIPPLE, 1/2X2, GALVANIZED STEEL		3
16	98248001	GAUGE, WATER PRESSURE (0-300 PSI)		2
15	98174408	ELBOW, STREET, 1/4", GALV.		1
14	98174405	ELBOW, 2", MALL IRON, GALV.		2
13	98174404	ELBOW, 1/4", MALL IRON, GALV.		2
12	98174400	ELBOW, STREET, 1/2", GALV.		1
11	98048022	BUSHING, REDUCER, 3/4X1/2, GALVANIZED		1
10	98048000	BUSHING, REDUCER, 1/2X1/4, GALVANIZED		1
9	96920944	HOSE, FLEXIBLE, STAINLESS STEEL, 1/4 NPT X 18 LONG		1
8	96920912	FLEX LINE, 12		1
7	96816906	VALVE, CHECK, MALE 1/2, MALE 1/2		1
6	96606607	TEE, 1/2X1/2X1/4, GALVANIZED		1
5	92056810	CONNECTOR, 3/8" ID TUBE x 1/2" NPT		1
4	92056704	CONNECTOR, ELBOW, 3/8" ID TUBE x 1/2" NPT		2
3	78653800	ASSEMBLY, BALL DRIP, 1/2"		1
2	78653004	ASSEMBLY, VALVE CAUTION STATION, 1/2"		1
1	78653000	ASSEMBLY, MANUAL EMERGENCY STATION		1

BILL OF MATERIALS

THIS DRAWING CONTAINS INFORMATION PROPRIETARY TO THE RELIABLE AUTOMATIC SPRINKLER CORP. IT MAY NOT BE REPRODUCED NOR MAY ANY INFORMATION HEREON BE DISCLOSED TO OTHERS WITHOUT THE SPECIFIC WRITTEN PERMISSION OF RELIABLE.

MTL: N/A
 FINISH:
 DO NOT SCALE DRAWING
 REMOVE BURRS, BREAK SHARP EDGES
 TOLERANCE UNLESS OTHERWISE SPECIFIED:
 ANGLE ± 1/2° 63'
 MACH. FINISH
 CONC. TIR
 SQUARENESS - PARALLELISM

THE RELIABLE AUTOMATIC SPRINKLER CO., INC.
 LIBERTY, S.C.
 PART NO: 77000266 DWG. SIZE: D
 PART: SUB-ASSEMBLY, TRIM, BASE, GALVANIZED PIPE
 PRODUCT: DDX 4", 6", 8"
 FILE NO: 77000266 ENG: JJ DRW BY: PH C'K'D:
 SCALE: 1:3 DATE: 07/13/17 SHEET 2 of 2

MODEL DDX VALVE WITH STAINLESS STEEL SCREW-IN SEAT

IMPORTANT NOTE: Early generation 4" and 6" DDX valves may incorporate a brass drop-in seat. Prior to ordering replacement parts, confirm the presence of a stainless steel screw-in seat or brass drop-in seat. For replacement parts for valves with brass drop-in seat, please contact Reliable Sprinkler Company Technical Services (techserv@reliablesprinkler.com)

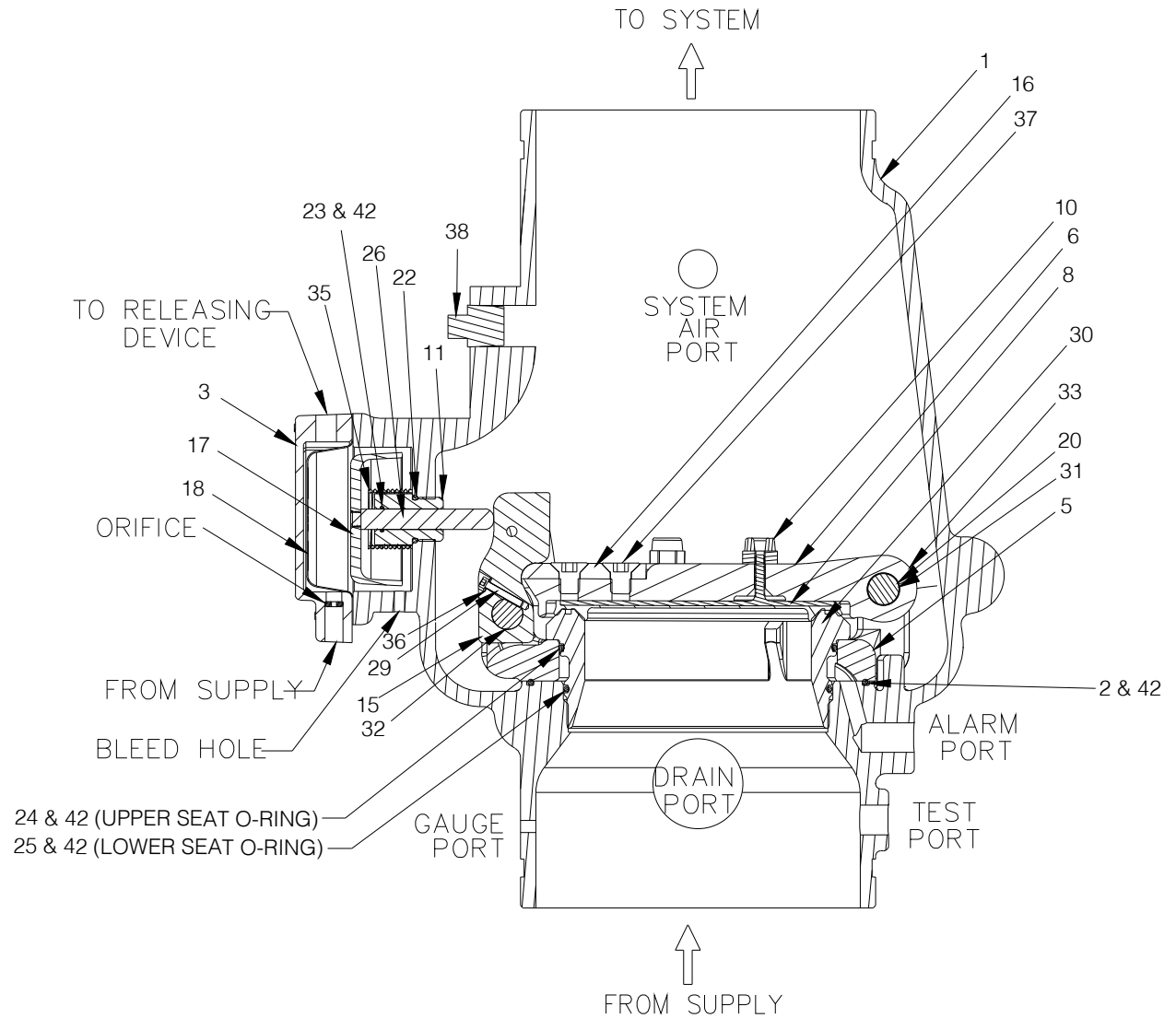
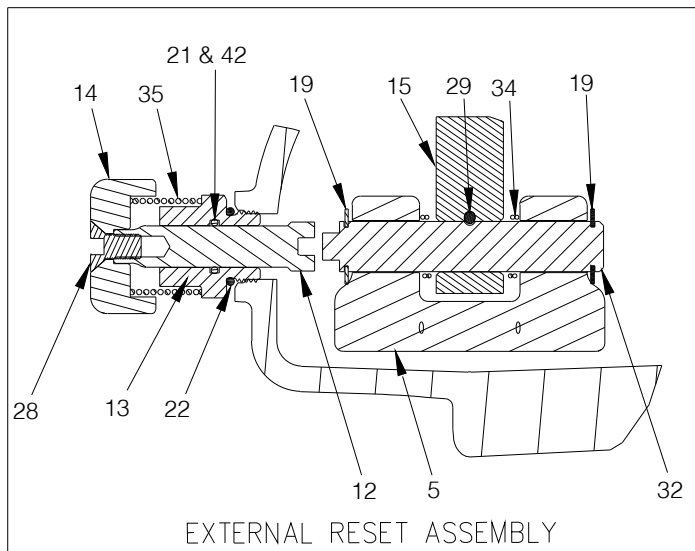
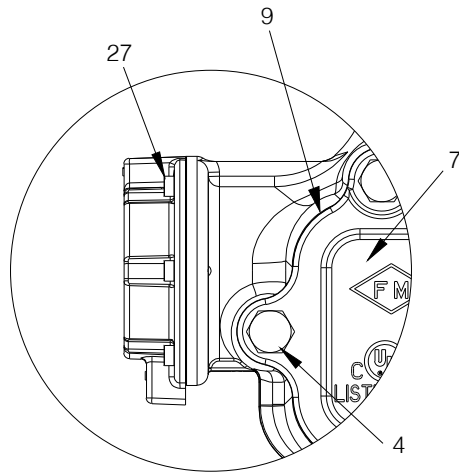

Model DDX (Screw-In Seat Configuration) Deluge Valves Parts List

Item No.	Part No.								Part Description	QTY.	Material
	2" (50mm)	2½" (65mm)	76mm	3" (80mm)	4" (100mm)	165mm	6" (150mm)	8" (200mm)			
1	91006011	91006012	91006023	91006013	91006005	91006027	91006007	91006028	Valve Body Groove/Groove	1	Ductile Iron 65-45-12
	N/A	N/A	N/A	N/A	91006045	N/A	91006067	N/A	Valve Body Flange/Groove		
	N/A	N/A	N/A	N/A	91006035	N/A	91006037	91006039	Valve Body Flange/Flange		
2	N/A	N/A	N/A	N/A	N/A	N/A	N/A	95406414	O-ring (Mounting Ring)	1	Buna-N
3	71040416								Pushrod Cover Assembly	1	Ductile Iron 65-45-12 & Brass C360000
4	91106123			N/A		N/A		N/A	Hex Bolt ½"-13 x 1¼"	6	Zinc Plated Steel
	N/A			95606107		N/A		N/A	Hex Bolt ½"-13 x 1½"	6	
	N/A			N/A		91106006		N/A	Hex Bolt ⅝"-11 x 1¾"	6	
	N/A			N/A		N/A		95606110	Hex Bolt ⅝"-11 x 2"	8	
5	91306013			91306014		91306016		91306018	Mounting Ring	1	Stainless Steel CF8 or CF8M
6	91916003			91916014		91916016		91916008	Clapper	1	Stainless Steel CF8 or CF8M
7	92116063			92116064		92116065	92116066	92116068	Access Cover	1	Ductile Iron 65-45-12
8	93416003			93416014		93416016		93416008	Seal Assembly	1	Stainless Steel 304 & EPDM
9	93706003			93706004		93706006		93706008	Access Cover Gasket	1	Buna-N or Neoprene
10	93722000			93722000		N/A		N/A	Bumpstop Assembly	1	Stainless Steel UNS S31600 & EPDM
	N/A			N/A		93722000		N/A		2	
	N/A			N/A		N/A		93722000		3	
11	93916006			93916006		93916006		93916006	Pushrod Guide	1	Acetal
12	93916006			93916006		93916006		93916006	Reset Shaft	1	Brass UNS C36000
13	94106006			94106006		94106006		94106006	Reset Housing	1	Brass UNS C36000
14	94356006			94356006		94356006		94356006	Reset Knob	1	Aluminum 6061
15	94506003			94506004		94506016		94506008	Lever	1	Stainless Steel UNS S17400
16	95006412			94006412		95006410		95006410	Striker	1	Aluminum Bronze C95400
17	95106006			95106006		95106006		95106006	Piston	1	Stainless Steel CF8M
18	95276006			95276006		95276006		95276006	Diaphragm	1	EPDM & Polyester
19	95306267			N/A		N/A		N/A	Retaining Ring, ⅜" Shaft, Lever Pin	2	Stainless Steel 15-7 or 17-7
	N/A			95306267		N/A		N/A	Retaining Ring, ½" Shaft, Lever Pin		
	N/A			N/A		95306269		N/A	Retaining Ring, ⅝" Shaft, Lever Pin		
	N/A			N/A		N/A		95316408	Retaining Ring, ¾" Shaft, Lever Pin		
20	95306268			N/A		N/A		N/A	Retaining Ring, ⅝" Shaft, Hinge Pin	2	Stainless Steel 15-7 or 17-7
	N/A			95306267		95306267		N/A	Retaining Ring, ½" Shaft, Hinge Pin		
	N/A			N/A		N/A		95316408	Retaining Ring, ¾" Shaft, Hinge Pin		
21	95406007			95406007		95406007		95406007	O-Ring, Reset Housing ID	1	Buna-N
22	95406024			95406024		95406024		95406024	O-Ring, Reset Housing & Pushrod Guide OD	2	Buna-N
23	95406407			95406407		95406407		95406407	O-Ring, Pushrod Guide ID	1	Buna-N
24	95406410			95406409		95436126		95406413	O-Ring, Upper Seat	1	Buna-N
25	95406411			95406420		95446226		95406412	O-Ring, Lower Seat	1	Buna-N
26	95506006			95506006		95506006		95506006	Pushrod	1	Stainless Steel UNS S30300
27	95606114			95606114		95606114		95606114	Socket Head Screw, ¼"-20 x ⅝"	6	Steel
28	95606127			95606127		95606127		95606127	Flat Head Socket Cap Screw ⅜"-16 x ¾"	1	Steel
29	95606133			N/A		N/A		N/A	Socket Head Screw #6-32 x ½"	1	Stainless Steel 18-8
	N/A			95606130		95606130		95606130	Socket Head Screw #10-32 x 1"		Stainless Steel UNS S31600
30	96016003			96016014		96016016		96016008	Seat	1	Stainless Steel CF8M
31	96206003			N/A		N/A		N/A	Hinge Pin	1	Stainless Steel UNS S30400
	N/A			96216086		9216086		96206008			Stainless Steel UNS S21800
32	96216003			N/A		N/A		N/A	Lever Pin	1	Stainless Steel UNS S17400
	N/A			96216044		96216047		96216008			Stainless Steel UNS S21800
33	96310003			96906904		96906904		96310008	Clapper Spacer	2	Teflon or Acetal
34	96406003			N/A		N/A		N/A	Lever Spring	1	Stainless Steel UNS S30400
	N/A			96406004		96406005		96406008			Stainless Steel UNS S31600
35	96406906			96406906		96406906		96406906	Piston/ Reset Spring	2	Stainless Steel UNS S31600
36	96906112			N/A		N/A		N/A	Spring Lock Washer, #6	1	Stainless Steel 18-8
	N/A			96906111		96906111		96906111	Spring Lock Washer, #10		Stainless Steel UNS S31600
37	95606140			N/A		N/A		N/A	Flat Head Socket Cap Screw ¼"-20 x ½"	2	Stainless Steel 18-8
	N/A			95606139		N/A		N/A			Stainless Steel UNS S31600
	N/A			N/A		N/A		95606135			Flat Head Socket Cap Screw ½"-13 x ¾"
38	98604402			98604402		98604402		98604402	Plug, ½" NPT	1	Steel
39	94616921			94616921		94616921		94616921	Knob Caution Label (Not Shown)	1	Polystyrene
40	91556922			91556922		91556922		91556922	Ball Chain, 1/8" (Not Shown) (Length is in Inches)	6	Nickel Plated Brass
41	91556923			91556923		91556923		91556923	Clamping Link, Ball Chain (Not Shown)	1	
42	699993406			699993406		699993406		699993406	O-Ring Grease, Dupont™ Krytox® GPL-205	A/R	Krytox®