

DDX VALVE PART NUMBER TABLE

DDX VALVE	VALVE PART NUMBER	DRAWING FILE NUMBER
2" DUCTILE IRON G/G BLACK	6103022000	6103030000
2" DUCTILE IRON G/G RED	6103022001	
2-1/2" DUCTILE IRON G/G BLACK	6103022500	
2-1/2" DUCTILE IRON G/G RED	6103022501	
3" DUCTILE IRON G/G BLACK	6103030000	
3" DUCTILE IRON G/G RED	6103030001	
76MM DUCTILE IRON G/G RED	6103027600	

MODEL DDX 2"-3" DELUGE DOUBLE INTERLOCK TYPE D CA-190 P/N 89241152 REV. G

ITEM NO.	PART NO.	DESCRIPTION	QTY.
29	89141112	TIE, RETAINING	9
28	9666756	TUBING, PVC, 3/8" I.D. x 6 FT	1
27	95516915	PERMA-LOK	A/B
26	98174400	ELBOW, STREET, 1/2", GALV.	1
25	9816906	VALVE CHECK, MALE 1/2, MALE 1/2	1
24	98840237	VALVE BALL, 1/4" NPT x 1/4" NPT	1
23	98815204	UNION, ORING SEAL, GALV., 1/2	1
22	98761651	TEE, 1/2x1/2x1/2, GALVANIZED	1
21	77000263	SUB-ASSEMBLY, TRIM, BASE, GALVANIZED PIPE	1
20	99800002	PAD-ADHESIVE, VALVE NAME PLATES	1
19	98543243	NIPPLE, 1/4x4, GALVANIZED STEEL	1
18	98543230	NIPPLE, 1/2x3, GALVANIZED STEEL	1
17	98543210	NIPPLE, 1/2x2-1/2, GALVANIZED STEEL	2
16	98543223	NIPPLE, 1/2x1-1/2, GALVANIZED STEEL	2
15	94616918	NAMEPLATE, DOUBLE INTERLOCK, TYPE D	1
14	6304001110	MODEL A PRESSURE MAINTENANCE DEVICE	1
13	91004299	MANIFOLD, DRAIN, BARBED, 6-3/16	1
12	98248000	GAUGE, AIR PRESSURE (0-90 PSI)	2
11	98174408	ELBOW, STREET, 1/4", GALV.	1
10	98174404	ELBOW, 1/4", MALL IRON, GALV.	1
9	98174401	ELBOW, 1/2", MALL IRON, GALV.	2
8	9256704	CONNECTOR, ELBOW, 3/8" ID TUBE x 1/2" NPT	1
7	95306255	CLAMP, HOSE, 1/2" CONSTANT TENSION, ZINC	8
6	98048022	BUSHING, REDUCER, 3/4x1/2, GALVANIZED	1
5	98048000	BUSHING, REDUCER, 1/2x1/4, GALVANIZED	1
4	77000303	SUBASSEMBLY, CONTROL VALVE, 3"	FULLY ASSEMBLED WITH CONTROL VALVE ONLY
	77000302	SUBASSEMBLY, CONTROL VALVE, 2-1/2"	
	77000301	SUBASSEMBLY, CONTROL VALVE, 2"	
3	6871020033	VALVE, SOLENOID (300 PSI) EXPLOSION PROOF	300 PSI EX. PROOF
	699990322	VALVE, SOLENOID (175 PSI) EXPLOSION PROOF	175 PSI EX. PROOF
	6871020020	VALVE, SOLENOID (300 PSI)	300 PSI RATED
	6871020000	VALVE, SOLENOID (175 PSI)	175 PSI RATED
	6871000000	VALVE, SOLENOID (232 PSI)	232 PSI RATED
2	6990012997	SWITCH, POTTER PRESSURE (PS10-EX)	(ULC, UL, FM)
	6990006382	SWITCH, PRESSURE POTTER (PS10-2)	(ULC, UL, FM)
	699992360	SWITCH, PRESSURE (EPSA10-2)	(ULC)
1	6999991212	SWITCH, PRESSURE (EPS10-2)	(UL/FM)
1	SEE DDX VALVE P/N TABLE		1

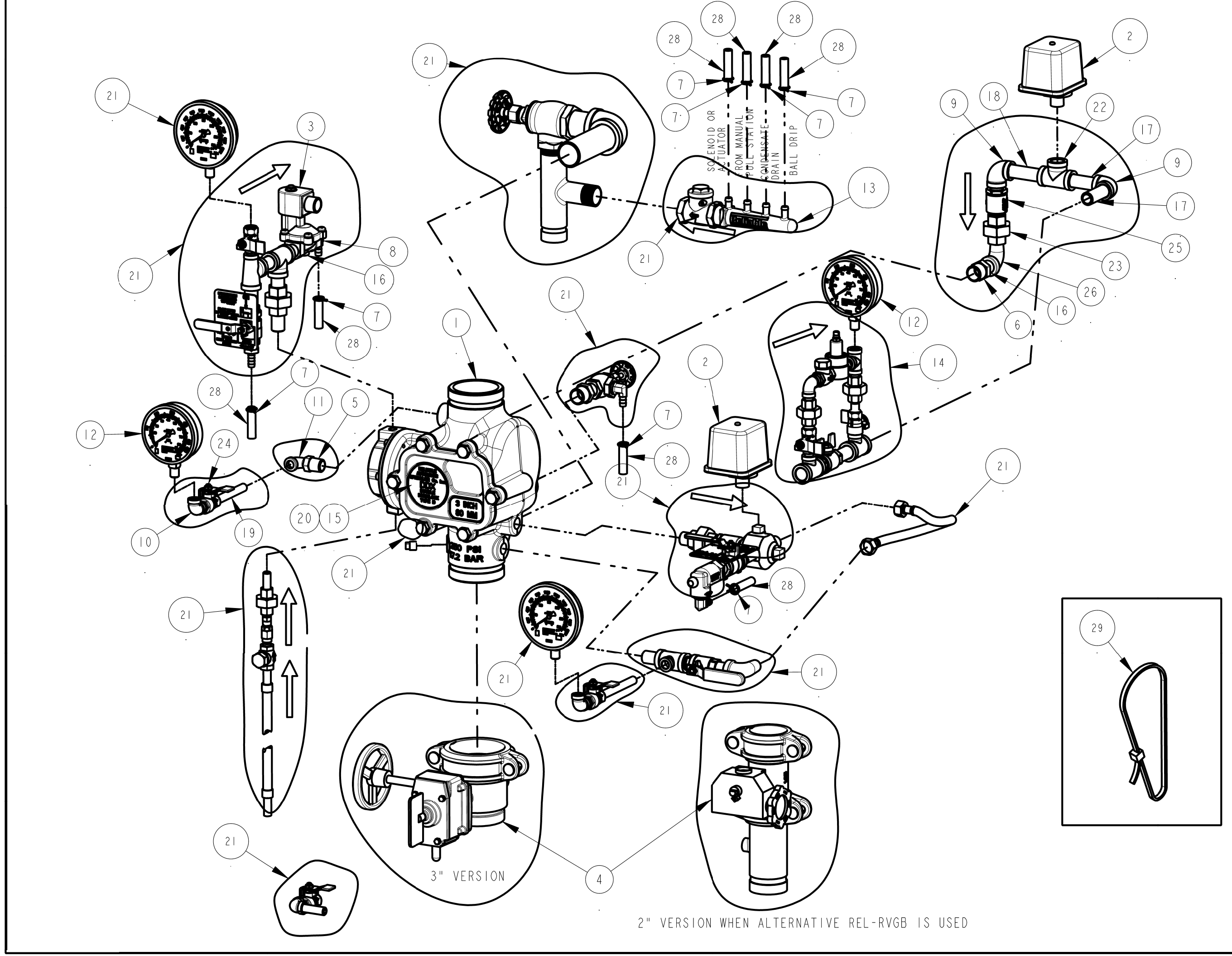

BILL OF MATERIALS

THIS DRAWING CONTAINS INFORMATION PROPRIETARY TO THE RELIABLE AUTOMATIC SPRINKLER CORP. IT MAY NOT BE REPRODUCED NOR MAY ANY INFORMATION HEREON BE DISCLOSED TO OTHERS WITHOUT THE SPECIFIC WRITTEN PERMISSION OF RELIABLE.

MFL N/A		THE RELIABLE AUTOMATIC SPRINKLER CO., INC. LIBERTY, SC.	
DO NOT SCALE DRAWING REMOVE BURRS, BREAK SHARP EDGES TOLERANCE UNLESS OTHERWISE SPECIFIED: ANGLE = 1/2° MACH FINISH CONC. TIR SQUARENESS - PARALLELISM	FRACT. = 1/32 (0.79) DEC. XX = 00 (0.25) DEC. XXX = 005 (0.05) 8540-2	FILE NO. ENG. J.J. 6520100110	SCALE: 1:6 DATE: 12/08/17
PART NO. VARIOUS		DWG. SIZE E	
PART: ASSEMBLY, TRIM, DOUBLE INTERLOCK, TYPE D		PRODUCT: DDX, 2", 2 1/2", 3"	
DRW BY: PH	CKD: -	SHEET 26/3	

REVISIONS			
LTR	DESCRIPTION	DATE	DRAWN BY
	SEE PAGE 1		

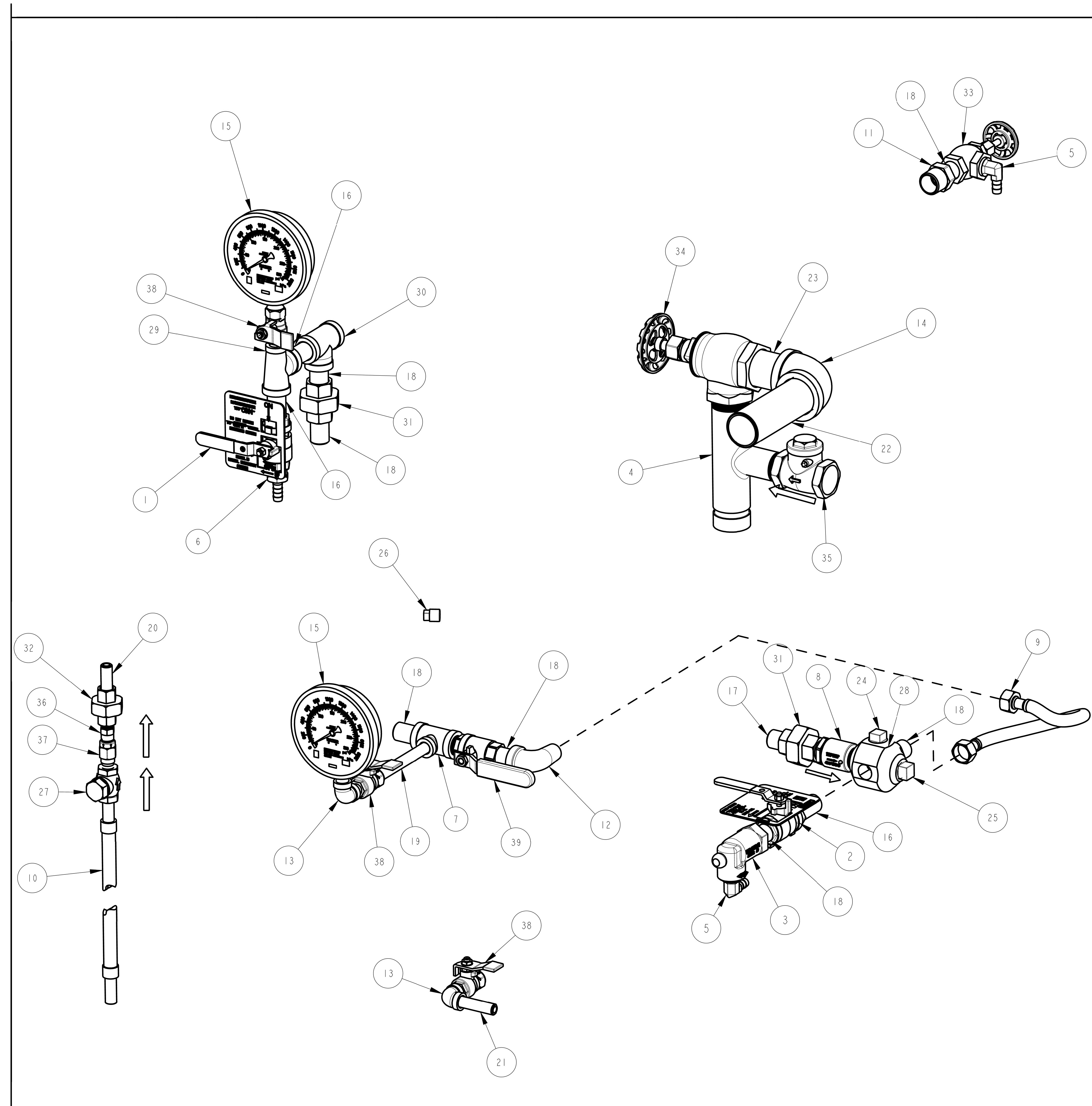

MODEL DDX 2"-3" BASIC TRIMS
 CA-323
 SUBASSEMBLY P/N 77000263 REV. E

ITEM NO.	PART NO.	DESCRIPTION	REMARKS	QTY.
40	95516915	THREAD, SEALANT	NOT SHOWN	A/R
39	9884011A	VALVE, BALL, 1/2 NPTF X 1/2 NPTM		1
38	98840237	VALVE, BALL, 1/4" NPTF x 1/4" NPTM		3
37	98840188	VALVE, CHECK, 1/4" NPTM x 1/4" NPTF		1
36	98840147	CHECK VALVE, 1/4, NPT, POPPET TYPE INLINE		1
35	98840145	SWING CHECK VALVE, 1" NPT		1
34	98840106	VALVE, ANGLE, 1 1/4		1
33	98840103	VALVE, ANGLE, 1/2"		1
32	98815201	UNION, 1/4, IRON, G. J., GALV.		1
31	98815200	UNION, 1/2, IRON, G. J., GALV.		2
30	98761651	TEE, 1/2X1/2X1/2, GALVANIZED		1
29	98761649	TEE, 1/2X1/4X1/2, GALVANIZED		1
28	98751005	FITTING, MULTIPOINT, 3/4x1/2x1/2x1/2x1/2		1
27	98727607	STRAINER, 1/4"		1
26	98614403	PIPE, PLUG, IRON, SQUARE HEAD, 1/4		1
25	98614401	PIPE, PLUG, IRON, SQUARE HEAD, 3/4		1
24	98604406	PIPE, PLUG, IRON, SQUARE HEAD, 1/2		1
23	98543285	NIPPLE, 1-1/4XCLOSE, GALVANIZED STEEL		1
22	98543284	NIPPLE, 1-1/4X5, GALVANIZED STEEL		1
21	98543244	NIPPLE, 1/4X2, GALVANIZED STEEL		1
20	98543226	NIPPLE, 1/4X1-1/2, GALVANIZED STEEL		1
19	98543224	NIPPLE, 1/4X4-1/2, GALVANIZED STEEL		1
18	98543223	NIPPLE, 1/2X1-1/2, GALVANIZED STEEL		7
17	98543212	NIPPLE, 1/2XCLOSE, GALVANIZED STEEL		1
16	98543209	NIPPLE, 1/2X2, GALVANIZED STEEL		3
15	98248001	GAUGE, WATER PRESSURE (0-300 PSI)		2
14	98174414	ELBOW, 1-1/4", MALL IRON, GALV.		1
13	98174404	ELBOW, 1/4", MALL IRON, GALV.		2
12	98174400	ELBOW, STREET, 1/2", GALV.		1
11	98048022	BUSHING, REDUCER, 3/4X1/2, GALVANIZED		1
10	96920944	HOSE, FLEXIBLE, STAINLESS STEEL, 1/4 NPT X 18 LONG		1
9	96920912	FLEX LINE, 12		1
8	96816906	VALVE, CHECK, MALE 1/2, MALE 1/2		1
7	96606607	TEE, 1/2X1/2X1/4, GALVANIZED		1
6	92056810	CONNECTOR, 3/8" ID TUBE x 1/2" NPT		1
5	92056704	CONNECTOR, ELBOW, 3/8" ID TUBE x 1/2" NPT		2
4	9101423C	MANIFOLD, 1-1/4 X 1-1/4 X 1, GRV/THD/THD		1
3	78653800	ASSEMBLY, BALL DRIP, 1/2"		1
2	78653004	ASSEMBLY, VALVE CAUTION STATION, 1/2"		1
1	78653000	ASSEMBLY, MANUAL EMERGENCY STATION		1

BILL OF MATERIALS

MTL N/A	THE RELIABLE AUTOMATIC SPRINKLER CO., INC. LIBERTY, S.C.			
FINISH	PART NO. 77000263	DWG. SIZE: D		
DO NOT SCALE DRAWING REMOVE BURRS, BREAK SHARP EDGES TOLERANCE UNLESS OTHERWISE SPECIFIED: ANGLE ± 1/2° 63' MACH. FINISH CONC. T.I.R. SQUARENESS - PARALLELISM	PART: SUB-ASSEMBLY, TRIM, BASE, GALVANIZED PIPE			
	PRODUCT: DDX 2"-3"			
	FILE NO. 77000263	ENG: JJ	DRW BY: PH	CKD:
		SCALE: 1:3	DATE: 04/25/13	SHEET 2 of 2

THIS DRAWING CONTAINS INFORMATION PROPRIETARY TO THE RELIABLE AUTOMATIC SPRINKLER CORP. IT MAY NOT BE REPRODUCED NOR MAY ANY INFORMATION HEREON BE DISCLOSED TO OTHERS WITHOUT THE SPECIFIC WRITTEN PERMISSION OF RELIABLE.

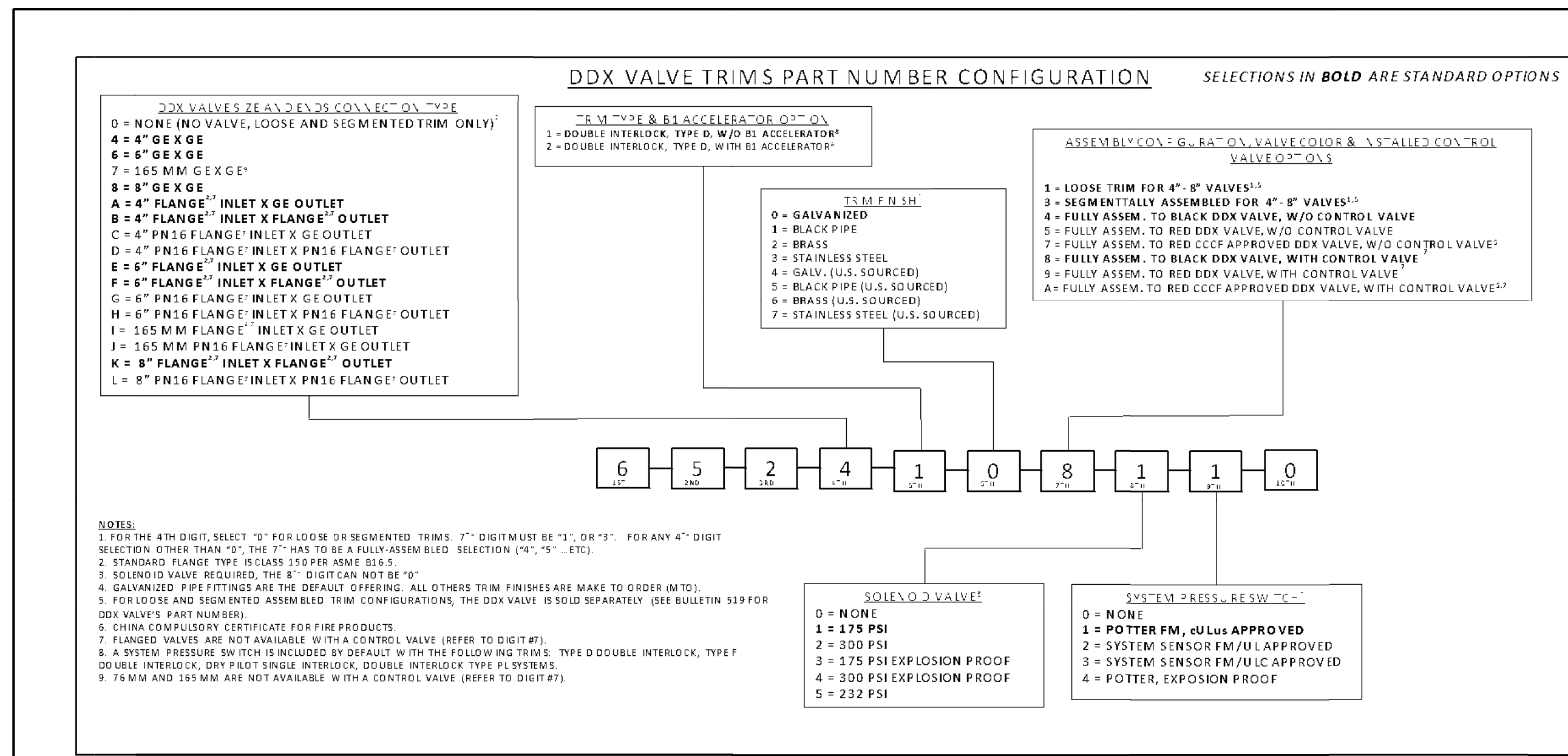

DDX VALVE PART NUMBER TABLE

DDX VALVE	VALVE PART NUMBER	DRAWING FILE NUMBER
4" DUCTILE IRON G/G BLACK	6103040026	
4" DUCTILE IRON G/G RED	6103040030	
4" DUCTILE IRON F/G CLASS 150 BLACK	6103040044	
4" DUCTILE IRON F/G CLASS 150 RED	6103040046	6103040026
4" DUCTILE IRON F/G PN16 RED	6103040048	
6" DUCTILE IRON F/G CLASS 150 BLACK	6103060045	
6" DUCTILE IRON F/G CLASS 150 RED	6103060047	
6" DUCTILE IRON F/G PN16 RED	6103060049	
6" DUCTILE IRON G/G BLACK	6103060024	
6" DUCTILE IRON G/G RED	6103060030	
6" DUCTILE IRON F/G CLASS 150 BLACK	6103060045	6103060024
6" DUCTILE IRON F/G CLASS 150 RED	6103060048	
6" DUCTILE IRON F/G PN16 RED	6103060049	
6" DUCTILE IRON F/F CLASS 150 BLACK	6103060046	
6" DUCTILE IRON F/F CLASS 150 RED	6103060047	
6" DUCTILE IRON F/F PN16 RED	6103060050	
165MM DUCTILE IRON G/G RED	6103060028	
165MM DUCTILE IRON F/G CLASS 150 RED	6103060051	6103060024
165MM DUCTILE IRON F/G PN16 RED	6103060052	
8" DUCTILE IRON G/G BLACK	6103080001	
8" DUCTILE IRON G/G RED	6103080003	
8" DUCTILE IRON F/G CLASS 150 BLACK	6103080016	6103080001
8" DUCTILE IRON F/G CLASS 150 RED	6103080018	
8" DUCTILE IRON F/F PN16 RED	6103080020	

MODEL DDX 4", 6" & 8" DELUGE DOUBLE INTERLOCK TYPE D
 CA-145 P/N 8924110

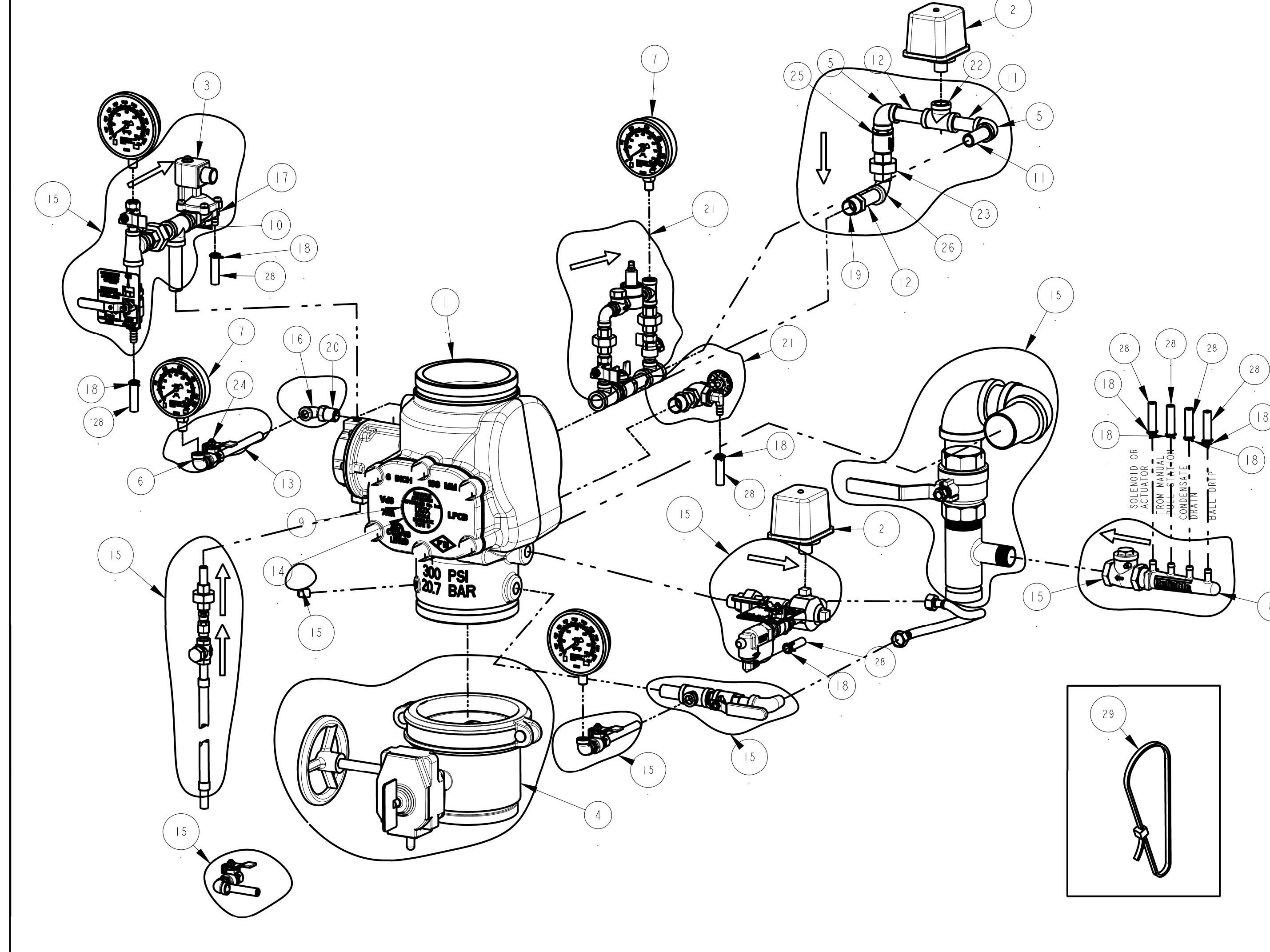

ITEM NO.	PART NO.	DESCRIPTION	QTY.
29	89141112	TIE, RETAINING	9
28	96686756	TUBING, PVC, 3/8" I.D. x 6 FT.	1
27	95516915	PERMA-LOK	NOT SHOWN A/R
26	98174400	ELBOW, STREET, 1/2", GALV.	1
25	96816906	VALVE, CHECK, MALE 1/2" MALE 1/2"	1
24	98840237	VALVE, BALL, 1/4" NPT x 1/4" NPTM	1
23	98815204	UNION, ORING SEAL, GALV., 1/2"	1
22	98761651	TEE, 1/2X1/2X1/2, GALVANIZED	1
21	6304001110	MODEL A PRESSURE MAINTENANCE DEVICE	1
20	98048000	BUSHING, REDUCER, 1/2X1/4, GALVANIZED	1
19	98048022	BUSHING, REDUCER, 3/4X1/2, GALVANIZED	1
18	95306255	CLAMP, HOSE, 1/2" CONSTANT TENSION, ZINC	8
17	92056704	CONNECTOR, ELBOW, 3/8" ID TUBE x 1/2" NPT	1
16	98174408	ELBOW, STREET, 1/4", GALV.	1
15	77000266	SUB-ASSEMBLY, TRIM, BASE, GALVANIZED PIPE	1
14	94080002	PAD-ADHESIVE, VALVE NAME PLATES	1
13	98543217	NIPPLE, 1/4X6, GALVANIZED STEEL	1
12	98543230	NIPPLE, 1/2X3, GALVANIZED STEEL	2
11	98543210	NIPPLE, 1/2X2-1/2, GALVANIZED STEEL	2
10	98543223	NIPPLE, 1/2X1-1/2, GALVANIZED STEEL	1
9	94616918	NAMEPLATE, DOUBLE INTERLOCK, TYPE D	1
8	91004299	MANIFOLD, DRAIN, BARBED, 6-3/16	1
7	98248000	GAUGE, AIR PRESSURE (0-80 PSI)	2
6	98174404	ELBOW, 1/4", MALL IRON, GALV.	1
5	98174401	ELBOW, 1/2", MALL IRON, GALV.	2
4	77000308	SUBASSEMBLY, CONTROL VALVE, 8"	FULLY ASSEMBLED WITH CONTROL VALVE ONLY
3	77000306	SUBASSEMBLY, CONTROL VALVE, 6"	
2	77000304	SUBASSEMBLY, CONTROL VALVE, 4"	
1	6871020033	VALVE, SOLENOID (300 PSI) EXPLOSION PROOF	300 PSI EX. PROOF
	6899990322	VALVE, SOLENOID (175 PSI) EXPLOSION PROOF	175 PSI EX. PROOF
	6871020020	VALVE, SOLENOID (300 PSI)	300 PSI RATED
	6871020000	VALVE, SOLENOID (175 PSI)	175 PSI RATED
	6871000000	VALVE, SOLENOID (232 PSI)	232 PSI RATED
	6990012997	SWITCH, PRESSURE POTTER (PSIO-EX)	(ULC, UL, FM)
	6990006382	SWITCH, PRESSURE POTTER (PSIO-2)	(ULC, UL, FM)
	6999992360	SWITCH, PRESSURE (EPSA10-2)	(ULC)
	6999991212	SWITCH, PRESSURE (EPSIO-2)	(UL/FM)
1	SEE DDX VALVE P/N TABLE		1

BILL OF MATERIALS

REVISIONS			
LTR	DESCRIPTION	DATE	DRAWN BY
	SEE PAGE 1		

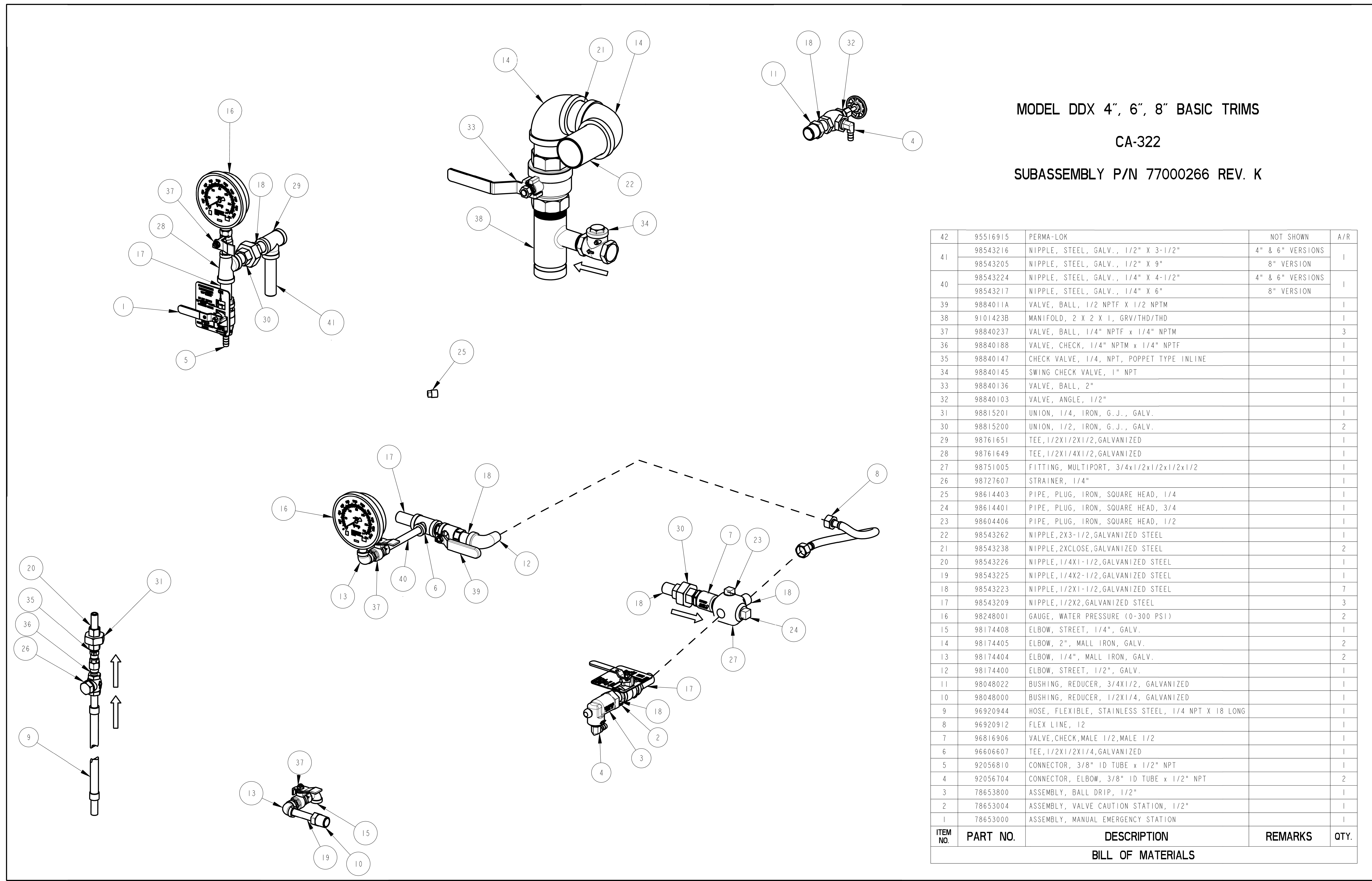

MODEL DDX 4", 6", 8" BASIC TRIMS
CA-322
SUBASSEMBLY P/N 77000266 REV. K

ITEM NO.	PART NO.	DESCRIPTION	REMARKS	QTY.
42	95516915	PERMA-LOK	NOT SHOWN	A/R
41	98543216	NIPPLE, STEEL, GALV., 1/2" X 3-1/2"	4" & 6" VERSIONS	1
	98543205	NIPPLE, STEEL, GALV., 1/2" X 9"	8" VERSION	
	98543224	NIPPLE, STEEL, GALV., 1/4" X 4-1/2"	4" & 6" VERSIONS	
40	98543217	NIPPLE, STEEL, GALV., 1/4" X 6"	8" VERSION	1
39	9884011A	VALVE, BALL, 1/2 NPTF x 1/2 NPTM		1
38	9101423B	MANIFOLD, 2 X 2 X 1, GRV/THD/THD		1
37	98840237	VALVE, BALL, 1/4" NPTF x 1/4" NPTM		3
36	98840188	VALVE, CHECK, 1/4" NPTM x 1/4" NPTF		1
35	98840147	CHECK VALVE, 1/4, NPT, POPPET TYPE INLINE		1
34	98840145	SWING CHECK VALVE, 1" NPT		1
33	98840136	VALVE, BALL, 2"		1
32	98840103	VALVE, ANGLE, 1/2"		1
31	98815201	UNION, 1/4, IRON, G. J., GALV.		1
30	98815200	UNION, 1/2, IRON, G. J., GALV.		2
29	98761651	TEE, 1/2X1/2X1/2, GALVANIZED		1
28	98761649	TEE, 1/2X1/4X1/2, GALVANIZED		1
27	98751005	FITTING, MULTIPORT, 3/4x1/2x1/2x1/2x1/2		1
26	98727607	STRAINER, 1/4"		1
25	98614403	PIPE, PLUG, IRON, SQUARE HEAD, 1/4		1
24	98614401	PIPE, PLUG, IRON, SQUARE HEAD, 3/4		1
23	98604406	PIPE, PLUG, IRON, SQUARE HEAD, 1/2		1
22	98543262	NIPPLE, 2X3-1/2, GALVANIZED STEEL		1
21	98543238	NIPPLE, 2XCLOSE, GALVANIZED STEEL		2
20	98543226	NIPPLE, 1/4X1-1/2, GALVANIZED STEEL		1
19	98543225	NIPPLE, 1/4X2-1/2, GALVANIZED STEEL		1
18	98543223	NIPPLE, 1/2X1-1/2, GALVANIZED STEEL		7
17	98543209	NIPPLE, 1/2X2, GALVANIZED STEEL		3
16	98248001	GAUGE, WATER PRESSURE (0-300 PSI)		2
15	98174408	ELBOW, STREET, 1/4", GALV.		1
14	98174405	ELBOW, 2", MALL IRON, GALV.		2
13	98174404	ELBOW, 1/4", MALL IRON, GALV.		2
12	98174400	ELBOW, STREET, 1/2", GALV.		1
11	98048022	BUSHING, REDUCER, 3/4X1/2, GALVANIZED		1
10	98048000	BUSHING, REDUCER, 1/2X1/4, GALVANIZED		1
9	96920944	HOSE, FLEXIBLE, STAINLESS STEEL, 1/4 NPT X 18 LONG		1
8	96920912	FLEX LINE, 12		1
7	96816906	VALVE, CHECK, MALE 1/2, MALE 1/2		1
6	96606607	TEE, 1/2X1/2X1/4, GALVANIZED		1
5	92056810	CONNECTOR, 3/8" ID TUBE x 1/2" NPT		1
4	92056704	CONNECTOR, ELBOW, 3/8" ID TUBE x 1/2" NPT		2
3	78653800	ASSEMBLY, BALL DRIP, 1/2"		1
2	78653004	ASSEMBLY, VALVE CAUTION STATION, 1/2"		1
1	78653000	ASSEMBLY, MANUAL EMERGENCY STATION		1

THIS DRAWING CONTAINS INFORMATION PROPRIETARY TO THE RELIABLE AUTOMATIC SPRINKLER CORP. IT MAY NOT BE REPRODUCED NOR MAY ANY INFORMATION HEREON BE DISCLOSED TO OTHERS WITHOUT THE SPECIFIC WRITTEN PERMISSION OF RELIABLE.

MTL: N/A
 FINISH:
 DO NOT SCALE DRAWING
 REMOVE BURRS, BREAK SHARP EDGES
 TOLERANCE UNLESS OTHERWISE SPECIFIED:
 ANGLE ± 1/2° 63'
 MACH. FINISH
 CONC. TIR
 SQUARENESS - PARALLELISM

THE RELIABLE AUTOMATIC SPRINKLER CO., INC.
 LIBERTY, S.C.
 PART NO: 77000266 DWG SIZE: D
 PART: SUB-ASSEMBLY, TRIM, BASE, GALVANIZED PIPE
 PRODUCT: DDX 4", 6", 8"
 FILE NO: 77000266 ENG: JJ DRW BY: PH C'K'D:
 SCALE: 1:3 DATE: 07/13/17 SHEET 2 of 2

MODEL DDX VALVE WITH STAINLESS STEEL SCREW-IN SEAT

IMPORTANT NOTE: Early generation 4" and 6" DDX valves may incorporate a brass drop-in seat. Prior to ordering replacement parts, confirm the presence of a stainless steel screw-in seat or brass drop-in seat. For replacement parts for valves with brass drop-in seat, please contact Reliable Sprinkler Company Technical Services (techserv@reliablesprinkler.com)

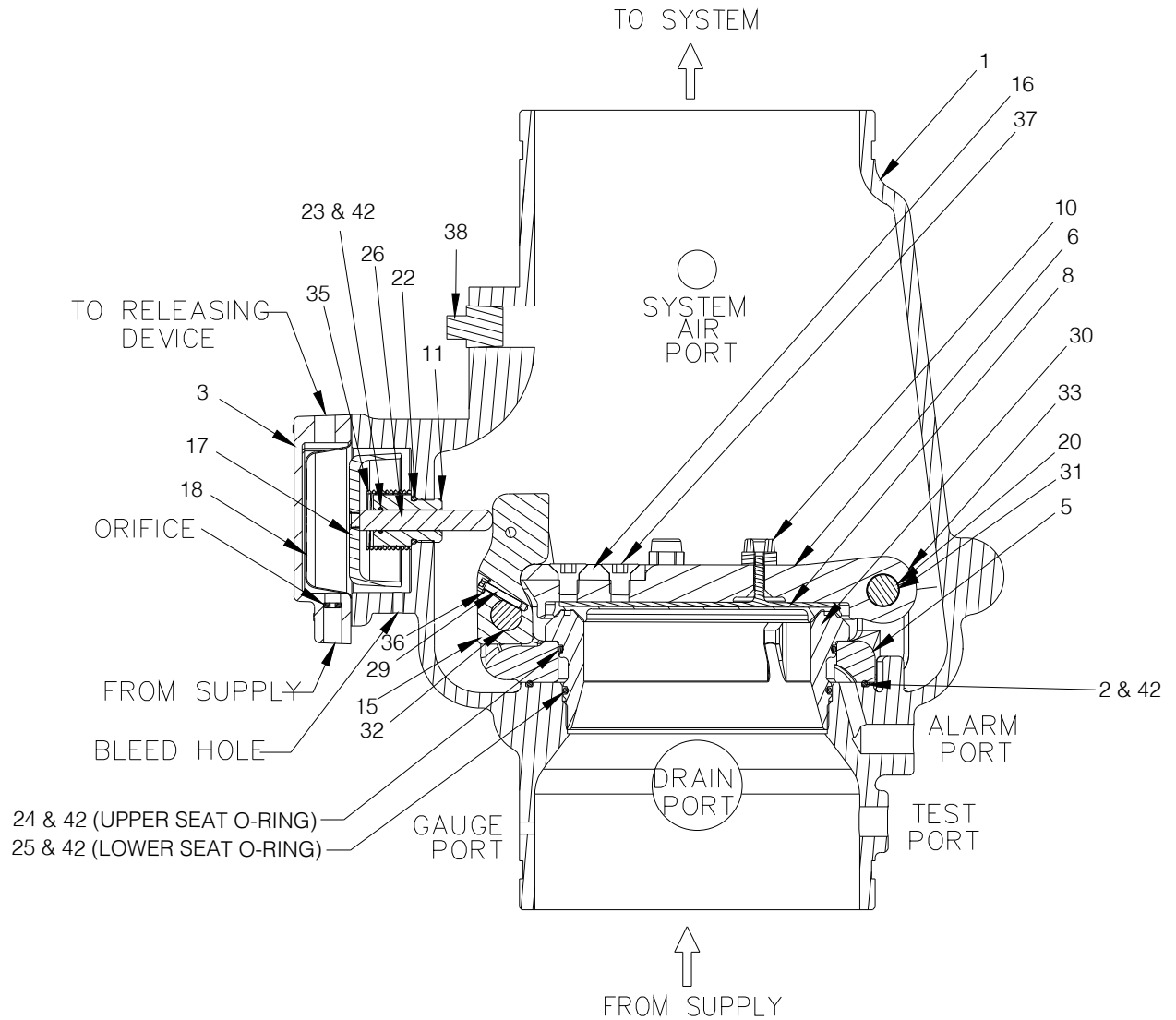
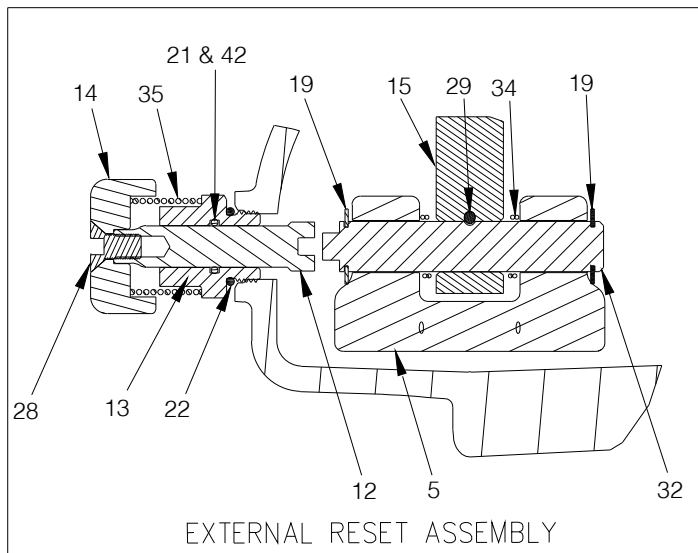
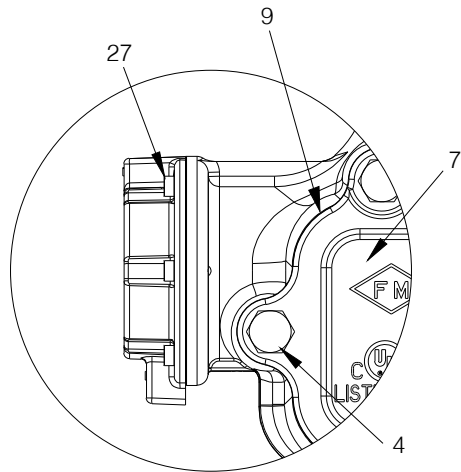

Model DDX (Screw-In Seat Configuration) Deluge Valves Parts List

Item No.	Part No.								Part Description	QTY.	Material
	2" (50mm)	2½" (65mm)	76mm	3" (80mm)	4" (100mm)	165mm	6" (150mm)	8" (200mm)			
1	91006011	91006012	91006023	91006013	91006005	91006027	91006007	91006028	Valve Body Groove/Groove	1	Ductile Iron 65-45-12
	N/A	N/A	N/A	N/A	91006045	N/A	91006067	N/A	Valve Body Flange/Groove		
	N/A	N/A	N/A	N/A	91006035	N/A	91006037	91006039	Valve Body Flange/Flange		
2	N/A	N/A	N/A	N/A	N/A	N/A	N/A	95406414	O-ring (Mounting Ring)	1	Buna-N
3	71040416								Pushrod Cover Assembly	1	Ductile Iron 65-45-12 & Brass C360000
4	91106123			N/A	N/A	N/A	N/A		Hex Bolt ½"-13 x 1¼"	6	Zinc Plated Steel
	N/A			95606107	N/A	N/A	N/A		Hex Bolt ½"-13 x 1½"	6	
	N/A			N/A	91106006	N/A	N/A		Hex Bolt ⅝"-11 x 1¾"	6	
	N/A			N/A	N/A	N/A	95606110		Hex Bolt ⅝"-11 x 2"	8	
5	91306013			91306014	91306016	91306018		Mounting Ring	1	Stainless Steel CF8 or CF8M	
6	91916003			91916014	91916016	91916008		Clapper	1	Stainless Steel CF8 or CF8M	
7	92116063			92116064	92116065	92116066	92116068	Access Cover	1	Ductile Iron 65-45-12	
8	93416003			93416014	93416016	93416008		Seal Assembly	1	Stainless Steel 304 & EPDM	
9	93706003			93706004	93706006	93706008		Access Cover Gasket	1	Buna-N or Neoprene	
10	93722000			93722000	N/A	N/A		Bumpstop Assembly	1	Stainless Steel UNS S31600 & EPDM	
	N/A			N/A	93722000	N/A			2		
	N/A			N/A	N/A	93722000			3		
11	93916006			93916006	93916006		93916006		Pushrod Guide	1	Acetal
12	93916006			93916006	93916006		93916006		Reset Shaft	1	Brass UNS C36000
13	94106006			94106006	94106006		94106006		Reset Housing	1	Brass UNS C36000
14	94356006			94356006	94356006		94356006		Reset Knob	1	Aluminum 6061
15	94506003			94506004	94506016	94506008		Lever	1	Stainless Steel UNS S17400	
16	95006412			94006412	95006410	95006410		Striker	1	Aluminum Bronze C95400	
17	95106006			95106006	95106006		95106006		Piston	1	Stainless Steel CF8M
18	95276006			95276006	95276006		95276006		Diaphragm	1	EPDM & Polyester
19	95306267			N/A	N/A	N/A		Retaining Ring, ⅜" Shaft, Lever Pin	2	Stainless Steel 15-7 or 17-7	
	N/A			95306267	N/A	N/A		Retaining Ring, ½" Shaft, Lever Pin			
	N/A			N/A	95306269	N/A		Retaining Ring, ⅝" Shaft, Lever Pin			
	N/A			N/A	N/A	95316408		Retaining Ring, ¾" Shaft, Lever Pin			
20	95306268			N/A	N/A	N/A		Retaining Ring, ⅝" Shaft, Hinge Pin	2	Stainless Steel 15-7 or 17-7	
	N/A			95306267	95306267	N/A		Retaining Ring, ½" Shaft, Hinge Pin			
	N/A			N/A	N/A	95316408		Retaining Ring, ¾" Shaft, Hinge Pin			
21	95406007			95406007	95406007		95406007		O-Ring, Reset Housing ID	1	Buna-N
22	95406024			95406024	95406024		95406024		O-Ring, Reset Housing & Pushrod Guide OD	2	Buna-N
23	95406407			95406407	95406407		95406407		O-Ring, Pushrod Guide ID	1	Buna-N
24	95406410			95406409	95436126	95406413		O-Ring, Upper Seat	1	Buna-N	
25	95406411			95406420	95446226	95406412		O-Ring, Lower Seat	1	Buna-N	
26	95506006			95506006	95506006		95506006		Pushrod	1	Stainless Steel UNS S30300
27	95606114			95606114	95606114		95606114		Socket Head Screw, ¼"-20 x ⅝"	6	Steel
28	95606127			95606127	95606127		95606127		Flat Head Socket Cap Screw ⅜"-16 x ¾"	1	Steel
29	95606133			N/A	N/A	N/A		Socket Head Screw #6-32 x ½"	1	Stainless Steel 18-8	
	N/A			95606130	95606130	95606130		Socket Head Screw #10-32 x 1"		Stainless Steel UNS S31600	
30	96016003			96016014	96016016	96016008		Seat	1	Stainless Steel CF8M	
31	96206003			N/A	N/A	N/A		Hinge Pin	1	Stainless Steel UNS S30400	
	N/A			96216086	9216086	96206008				Stainless Steel UNS S21800	
32	96216003			N/A	N/A	N/A		Lever Pin	1	Stainless Steel UNS S17400	
	N/A			96216044	96216047	96216008				Stainless Steel UNS S21800	
33	96310003			96906904	96906904	96310008		Clapper Spacer	2	Teflon or Acetal	
34	96406003			N/A	N/A	N/A		Lever Spring	1	Stainless Steel UNS S30400	
	N/A			96406004	96406005	96406008				Stainless Steel UNS S31600	
35	96406906			96406906	96406906		96406906		Piston/ Reset Spring	2	Stainless Steel UNS S31600
36	96906112			N/A	N/A	N/A		Spring Lock Washer, #6	1	Stainless Steel 18-8	
	N/A			96906111	96906111	96906111		Spring Lock Washer, #10		Stainless Steel UNS S31600	
37	95606140			N/A	N/A	N/A		Flat Head Socket Cap Screw ¼"-20 x ½"	2	Stainless Steel 18-8	
	N/A			95606139	N/A	N/A				Stainless Steel UNS S31600	
	N/A			N/A	N/A	95606135		Flat Head Socket Cap Screw ½"-13 x ¾"	Stainless Steel UNS S31600		
38	98604402			98604402	98604402		98604402		Plug, ½" NPT	1	Steel
39	94616921			94616921	94616921		94616921		Knob Caution Label (Not Shown)	1	Polystyrene
40	91556922			91556922	91556922		91556922		Ball Chain, 1/8" (Not Shown) (Length is in Inches)	6	Nickel Plated Brass
41	91556923			91556923	91556923		91556923		Clamping Link, Ball Chain (Not Shown)	1	
42	699993406			699993406	699993406		699993406		O-Ring Grease, Dupont™ Krytox® GPL-205	A/R	Krytox®