

Reliable®

PrePaK™

Factory Assembled

Fully Integrated Systems

**Installation,
Operation, and
Maintenance
Manual**



THIS PAGE LEFT INTENTIONALLY BLANK

Contents

IMPORTANT: This manual is provided to assist with the installation, operation, and maintenance of the Reliable Automatic Sprinkler Company PrePaK™. It is imperative that this manual be completely read and understood before installation or use of the product. Save this manual for future reference.

1	Introduction	Page 1
2	Scope	Page 1
3	Product Descriptions and References	Pages 1-23
4	Placement and Anchoring	Page 24
5	Piping Connections	Page 24
6	Power Supply Connections	Page 25
7	Factory Wiring	Pages 25-30
8	Field Wiring: Units with Releasing Control Panel	Pages 31-36
9	Releasing Control Panel Programming	Pages 37-43
10	Field Wiring: Units without Releasing Control Panel	Pages 44-45
11	Addressable Fire Alarm Systems	Page 46
12	Supervisory Air/Nitrogen Pressure Requirements	Page 47-48
13	Setting and Resetting System	Page 49
14	Inspections	Page 50
15	Testing	Page 51
16	Maintenance	Page 52

List of Figures

Description	Page
Figure 1 Standard Cabinet Dimensions	2
Figure 2 Nitrogen Generator Cabinet Dimensions	3
Figure 3 Type D Single, Double, Interlock Preaction Components	5
Figure 4 Type F Double Interlock Preaction Components	7
Figure 5 DDX-LP Dry System Components	9
Figure 6 Wet Pilot Line Limitations	10
Figure 7 Deluge Wet Pilot Line System Components	11
Figure 8 Deluge Dry Pilot Line System Components	13
Figure 9 Deluge Electric Release System Components	15
Figure 10 Single Interlock Preaction Dry Pilot Line System Components	17
Figure 11 Wet Pilot Line Limitations	18
Figure 12 Single Interlock Preaction Wet Pilot Line System Components	19
Figure 13 Type PL Double Interlock Preaction System Components	21
Figure 14 Non-Interlock Preaction System Components	23
Figure 15 Factory Installed Electrical Devices	26
Figure 16 Potter PFC-4410G3 Releasing Control Panel	27
Figure 17 Pressure & Tamper Switch Wiring	28
Figure 18 Solenoid and Air Compressor Wiring	29
Figure 19 Optional CoilKeeper™ Wiring	30
Figure 20 24 VDC Terminal Block (Units with Integral Panel)	33
Figure 21 Class A Detector Circuit Wiring Example	34
Figure 22 Class B Detector Circuit Wiring Example	35
Figure 23 Output Device (Notification) Wiring Example	36
Figure 24 24VDC Terminal Block (Units without Integral Panel)	45
Figure 25 Supervisory Air/Nitrogen Pressure Requirements	48

1. Introduction

The Reliable Model DDX PrePaK™ is a completely self-contained, supervised system that can be readily installed within a floor space (not including door swing) of 4.7 ft² (0.43 m²) for 2" through 4" systems, and 6.5 ft² (0.60 m²) for 6" and 8" systems and those systems incorporating a nitrogen generator.

Installation of the PrePaK™ requires three piping connections: the water supply, the sprinkler system, and the drain. Reference locations of these piping connections, along with general PrePaK™ dimensions are shown on figures 1 and 2 of this document.

Individual power circuits are required for the releasing control panel, air compressor, and nitrogen generator, where so equipped. Depending on the type of system and requirements of the project, field wiring of detection devices and notification devices may be required. When equipped with an integral releasing control panel, connection of the panel to the main building fire alarm system may also be required.

2. Scope

This document is intended to provide detailed information on the installation, operation, and maintenance of Reliable Model DDX PrePaK™ cabinet mounted systems. Basic information for the selection and ordering of units is provided on technical bulletin 760 that is available on the Reliable website (www.reliablesprinkler.com).

This document does not contain information on the design, applicability, or installation of the automatic fire detection system that may be necessary for complete operation of the system. Design and installation of fire detection and alarm systems must be performed by qualified design professionals and approved by all authorities having jurisdiction.

This document is not intended to replace or revise any requirements of the National Fire Protection Association (NFPA), FM Global, and/or any authorities having jurisdiction (AHJ) that may govern an installation. Design and installation requirements for fire protection systems must be independently evaluated by qualified design professionals and approved by all authorities having jurisdiction.

3. Product Descriptions & References

Pages 4 through 23 provide descriptions of each available system, additional (related) product references, and diagrams of major system components. Full assembly drawings are available on the Reliable website (www.reliablesprinkler.com).

STANDARD UNIT DIMENSIONS INCHES [CM]

SYSTEM SIZE	A	B	C	D	E	F	G	H	J	K	L	M WITHOUT UPPER VALVE	M WITH UPPER VALVE
2" (50MM)	25.0 [63.5]	28.3 [71.8]	70.0 [177.8]	50.0 [127.0]	13.1 [33.2]	14.3 [36.3]	14.3 [36.3]	6.3 [16.0]	13.6 [34.5]	1.8 [4.5]	3.3 [8.3]	27.2 [69.0]	24.1 [61.2]
2-1/2" (65MM)	25.0 [63.5]	28.3 [71.8]	70.0 [177.8]	50.0 [127.0]	13.1 [33.2]	14.3 [36.3]	14.3 [36.3]	6.3 [16.0]	13.6 [34.5]	1.8 [4.5]	3.3 [8.3]	27.9 [70.8]	24.1 [61.2]
3" (80MM)	25.0 [63.5]	28.3 [71.8]	70.0 [177.8]	50.0 [127.0]	13.1 [33.2]	14.3 [36.3]	14.3 [36.3]	6.3 [16.0]	13.6 [34.5]	1.8 [4.5]	3.3 [8.3]	27.9 [70.8]	24.1 [61.2]
4" (100MM)	25.0 [63.5]	28.3 [71.8]	70.0 [177.8]	50.0 [127.0]	13.1 [33.2]	14.3 [36.3]	14.3 [36.3]	6.3 [16.0]	13.6 [34.5]	1.8 [4.5]	3.3 [8.3]	28.5 [72.3]	24.1 [61.2]
6" (150MM)	30.0 [76.2]	33.0 [88.8]	74.0 [188.0]	60.0 [152.4]	14.8 [37.5]	15.0 [38.1]	15.0 [38.1]	7.0 [17.7]	13.6 [34.5]	5.3 [13.4]	4.8 [12.1]	29.3 [74.4]	24.1 [61.2]
8" (200MM)	30.0 [76.2]	33.0 [88.8]	74.0 [188.0]	60.0 [152.4]	14.8 [37.5]	15.0 [38.1]	15.0 [38.1]	7.0 [17.7]	13.6 [34.5]	5.3 [13.4]	4.8 [12.1]	26.2 [66.5]	20.5 [52.0]

SOME COMPONENTS OMITTED FOR CLARITY

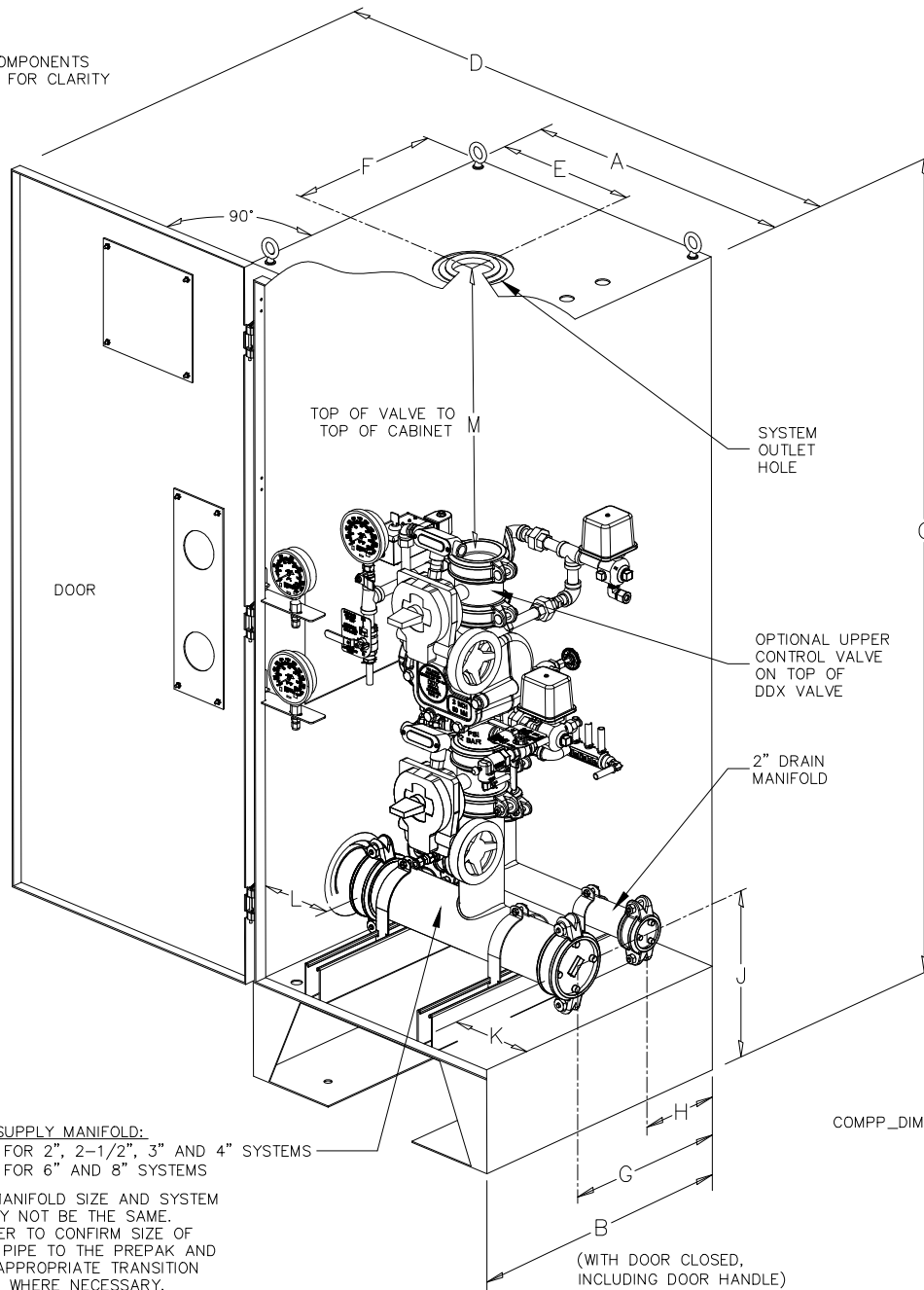

WATER SUPPLY MANIFOLD:
 4" PIPE FOR 2", 2-1/2", 3" AND 4" SYSTEMS
 8" PIPE FOR 6" AND 8" SYSTEMS

NOTE: MANIFOLD SIZE AND SYSTEM SIZE MAY NOT BE THE SAME. CUSTOMER TO CONFIRM SIZE OF SUPPLY PIPE TO THE PREPAK AND ORDER APPROPRIATE TRANSITION FITTINGS WHERE NECESSARY.

(WITH DOOR CLOSED, INCLUDING DOOR HANDLE)

NITROGEN GENERATOR UNIT DIMENSIONS INCHES [CM]

SYSTEM SIZE	A	B	C	D	E	F	G	H	J	K	L	M WITHOUT UPPER VALVE	M WITH UPPER VALVE
2" (50MM)	30.0 [76.2]	33.1 [84.0]	74.0 [188.0]	60.0 [152.4]	12.8 [32.4]	19.7 [50.0]	19.7 [50.0]	11.6 [29.4]	11.6 [29.4]	8.0 [20.3]	2.0 [5.1]	34.0 [86.3]	30.0 [76.2]
2-1/2" (65MM)	30.0 [76.2]	33.1 [84.0]	74.0 [188.0]	60.0 [152.4]	12.8 [32.4]	19.7 [50.0]	19.7 [50.0]	11.6 [29.4]	11.6 [29.4]	8.0 [20.3]	2.0 [5.1]	34.0 [86.3]	30.0 [76.2]
3" (80MM)	30.0 [76.2]	33.1 [84.0]	74.0 [188.0]	60.0 [152.4]	12.8 [32.4]	19.7 [50.0]	19.7 [50.0]	11.6 [29.4]	11.6 [29.4]	8.0 [20.3]	2.0 [5.1]	34.0 [86.3]	30.0 [76.2]
4" (100MM)	30.0 [76.2]	33.1 [84.0]	74.0 [188.0]	60.0 [152.4]	12.8 [32.4]	19.7 [50.0]	19.7 [50.0]	11.6 [29.4]	11.6 [29.4]	8.0 [20.3]	2.0 [5.1]	34.0 [86.3]	29.5 [74.9]
6" (150MM)	30.0 [76.2]	33.1 [84.0]	74.0 [188.0]	60.0 [152.4]	12.6 [32.0]	18.0 [45.7]	18.0 [45.7]	10.0 [25.4]	11.6 [29.4]	8.1 [20.6]	2.0 [5.1]	31.6 [80.3]	26.4 [67.1]

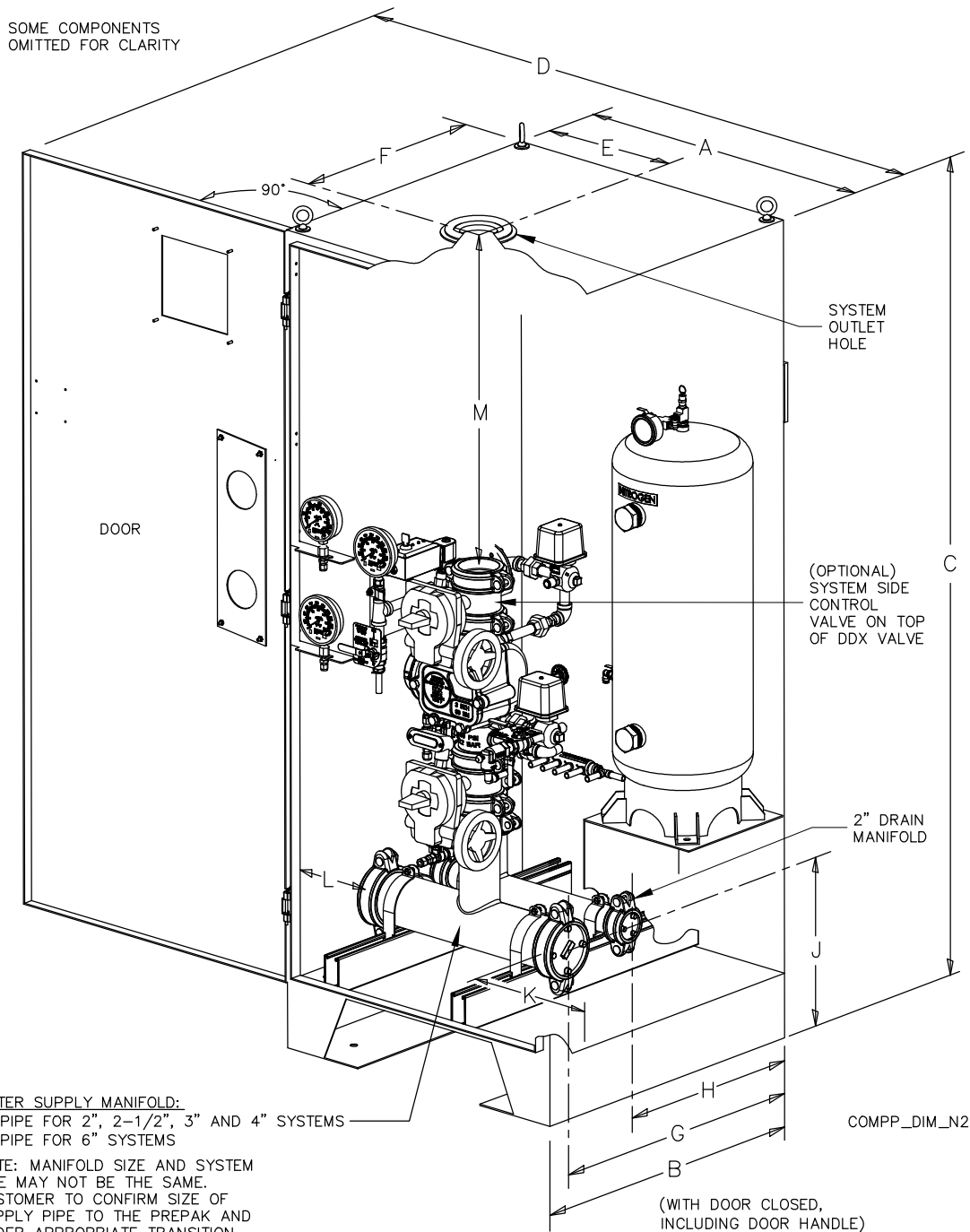

Product: Model DDX Type D Single/Double Interlock Preaction System

The Reliable Model DDX Type D preaction system is an electric release system that incorporates a 24VDC normally closed solenoid valve on the deluge valve releasing trim. The solenoid valve is energized by a listed release control panel and detection system when the appropriate type and number of events have occurred to satisfy the panel program.

For single interlock preaction systems, the activation of a supplemental electric detection system, either on a single zone or two zones (cross zoned) will energize the solenoid, releasing water into the system and initiating a water flow alarm.

For double interlock preaction systems, the activation of a supplemental electric detection system in conjunction with activation of the low-pressure switch due to loss of system pneumatic pressure (presumed due to a fire sprinkler opening) will energize the solenoid, releasing water into the system and initiating a water flow alarm.

In the event of pneumatic pressure loss on the system with no active electric detection, the pressure switch will operate independently, and a supervisory signal will report to the fire alarm system, however, water will not be released into the system.

This system, in sizes 2" through 6" (50 mm to 150 mm), is also available with an integral SouthTek Systems FPS-900 N2-Blast® nitrogen generator, FM Approved to Standard 1035, Nitrogen Generators for Corrosion Mitigation.

Reference Publications

- Model DDX PrePaK Basic Information [Reliable Technical Bulletin 760](#)
- Model DDX Deluge Valve [Reliable Technical Bulletin 519](#)
- Model DDX Type D Preaction System [Reliable Technical Bulletin 750](#)
- Water Flow Alarm Pressure Switch [Potter Electric Bulletin 5400928](#)
- Low Air Supervisory Pressure Switch [Potter Electric Bulletin 5400928](#)
- Release Control Disable Switch [Potter Electric Bulletin 5401214](#)
- Solenoid Valve [Reliable Technical Bulletin 718](#)
- Air Compressor [Reliable Technical Bulletin 256](#) (or)
[General Air](#)
- Pressure Maintenance Device [Reliable Technical Bulletin 251](#)
- Release Control Panel [Potter Electric Bulletin 5403751](#)

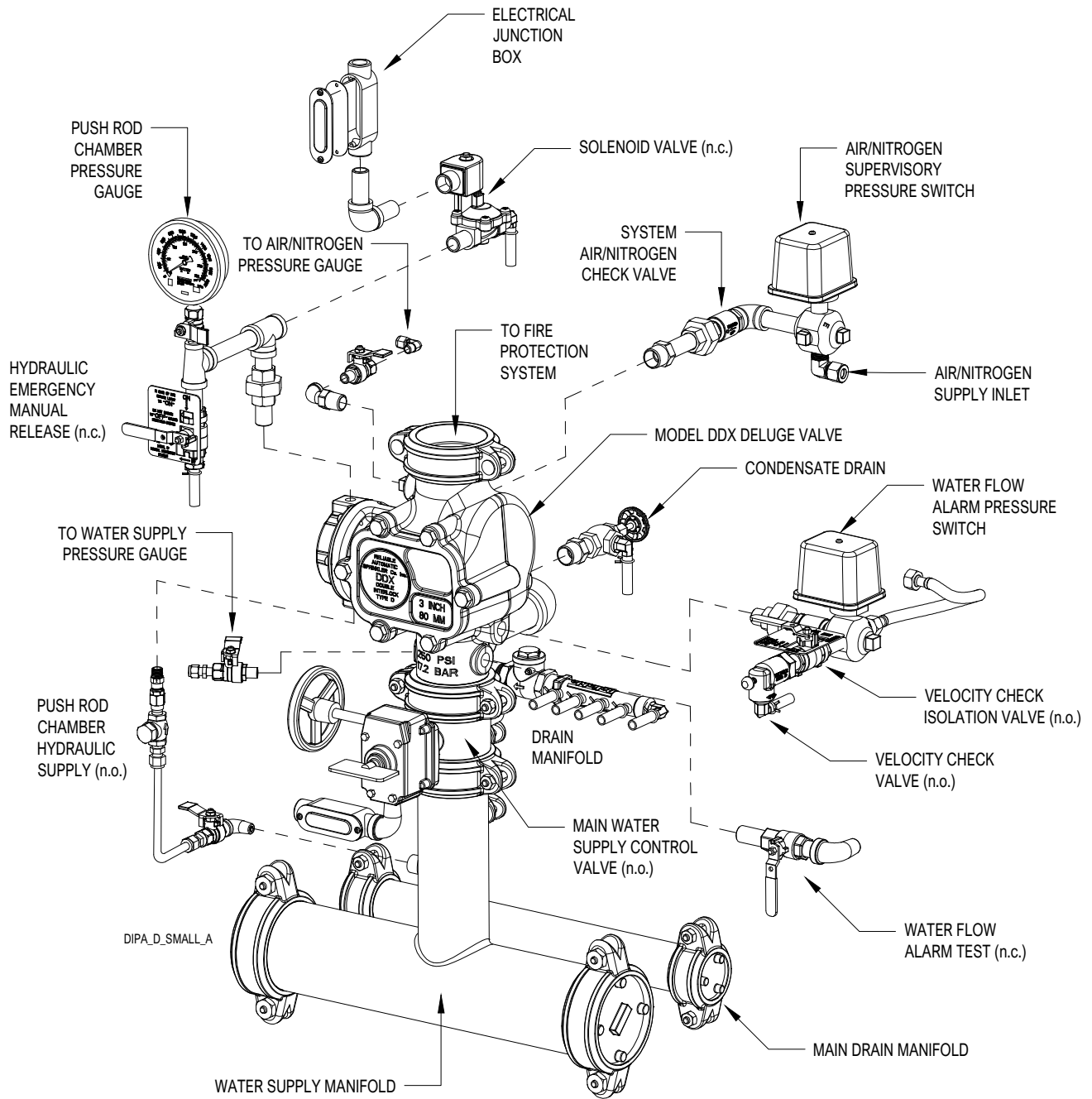

NOTES:

1. ALL COMPONENTS AND OPTIONS MAY NOT BE SHOWN.
2. DIAGRAM IS FOR REFERENCE ONLY AND MAY NOT REFLECT EXACT PRODUCT CONFIGURATION.
3. FULL ASSEMBLY DRAWINGS ARE AVAILABLE AT www.reliablesprinkler.com.

Product: Model DDX Type F Double Interlock Preaction System

The Reliable Model DDX Type F double interlock preaction system is an electric/pneumatic release system that incorporates a 24VDC normally closed solenoid valve in series with a Model LP low-pressure dry pilot actuator on the deluge valve releasing trim.

The activation of a supplemental electric detection system, either on a single zone or two zones (cross zoned) will energize the solenoid valve. Subsequent operation of the low-pressure dry pilot actuator due to loss of system pneumatic pressure (presumed due to a fire sprinkler opening) releases water into the system and initiates a water flow alarm.

In the event of pneumatic pressure loss on the system with no active electric detection, the pressure switch will operate independently, and a supervisory signal will report to the fire alarm system, however, water will not be released into the system.

This system, in sizes 2" through 6" (50 mm to 150 mm), is also available with an integral SouthTek Systems FPS-900 N2-Blast® nitrogen generator, FM Approved to Standard 1035, Nitrogen Generators for Corrosion Mitigation.

Reference Publications

- Model DDX PrePaK Basic Information [Reliable Technical Bulletin 760](#)
- Model DDX Deluge Valve [Reliable Technical Bulletin 519](#)
- Model DDX Type F Preaction System [Reliable Technical Bulletin 751](#)
- Water Flow Alarm Pressure Switch [Potter Electric Bulletin 5400928](#)
- Low Air Supervisory Pressure Switch [Potter Electric Bulletin 5401564](#)
- Release Control Disable Switch [Potter Electric Bulletin 5401214](#)
- Solenoid Valve [Reliable Technical Bulletin 718](#)
- Model LP Actuator [Reliable Technical Bulletin 505](#)
- Model B-1 Accelerator [Reliable Technical Bulletin 323](#)
- Air Compressor [Reliable Technical Bulletin 256](#) (or)
[General Air](#)
- Pressure Maintenance Device [Reliable Technical Bulletin 251](#)
- Release Control Panel [Potter Electric Bulletin 5403751](#)

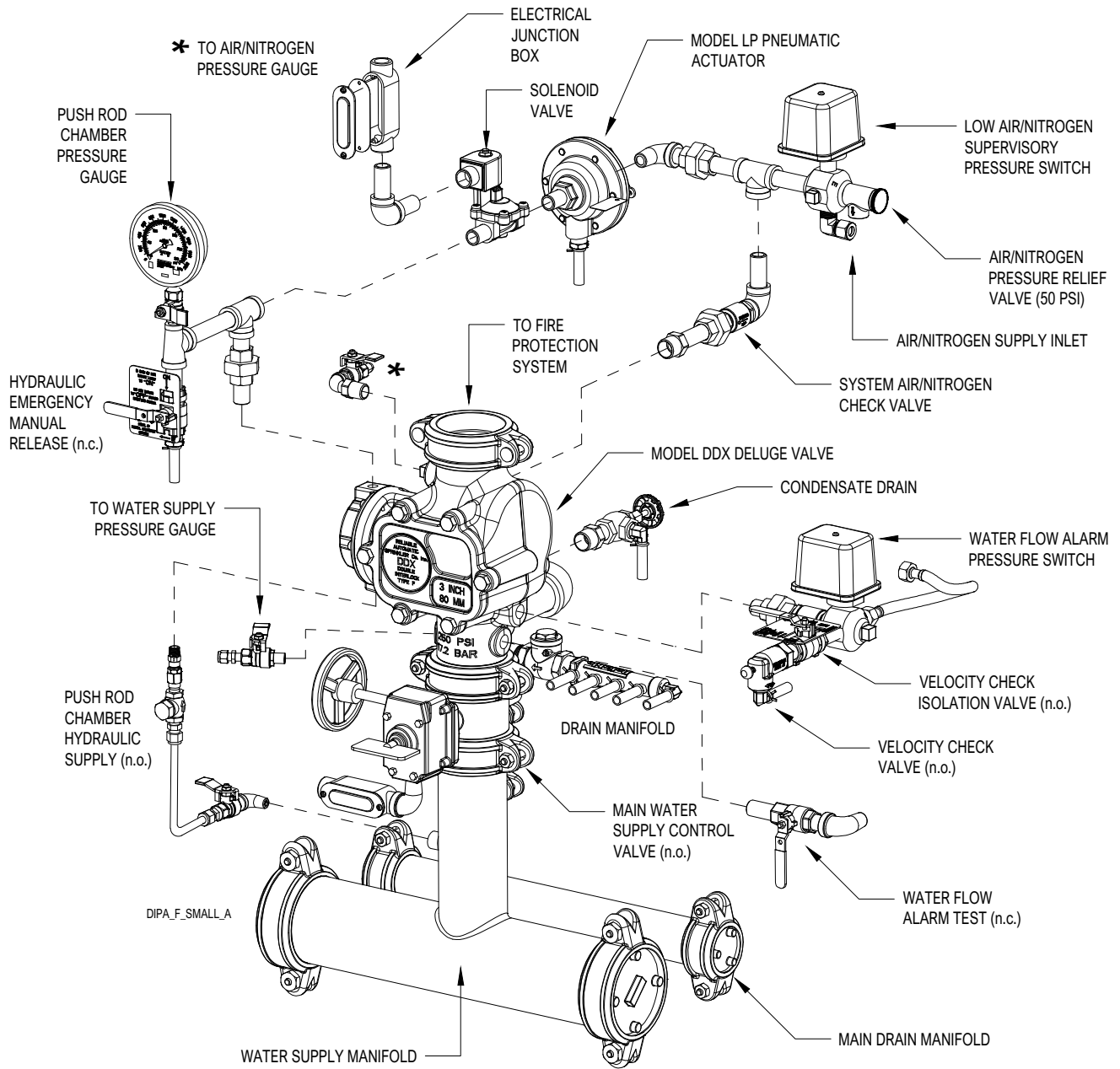

NOTES:

1. ALL COMPONENTS AND OPTIONS MAY NOT BE SHOWN.
2. DIAGRAM IS FOR REFERENCE ONLY AND MAY NOT REFLECT EXACT PRODUCT CONFIGURATION.
3. FULL ASSEMBLY DRAWINGS ARE AVAILABLE AT www.reliablesprinkler.com.

Product: Model DDX-LP Low Pressure Dry Pipe System

The Reliable Model DDX-LP is a dry pipe system that incorporates a low-pressure dry pilot actuator on the deluge valve releasing trim.

The Model LP dry pilot actuator is diaphragm operated valve that is normally held closed using the same air or nitrogen pressure contained in the dry pipe system. Loss of pneumatic pressure in the system (presumed due to a fire sprinkler operating) results in the opening of the dry pilot actuator, releasing water into the system and initiating a water flow alarm.

In the event of a slow loss of pneumatic pressure (such as a leak), the pressure switch will operate, and a supervisory signal will report to the fire alarm system.

Note: Failure to address a low-pressure condition may result in operation of the dry pipe system.

This system, in sizes 2" through 6" (50 mm to 150 mm), is also available with an integral SouthTek Systems FPS-900 N2-Blast® nitrogen generator, FM Approved to Standard 1035, Nitrogen Generators for Corrosion Mitigation.

Reference Publications

- Model DDX PrePaK Basic Information [Reliable Technical Bulletin 760](#)
- Model DDX Deluge Valve [Reliable Technical Bulletin 519](#)
- Model DDX-LP Dry Pipe System [Reliable Technical Bulletin 338](#)
- Water Flow Alarm Pressure Switch [Potter Electric Bulletin 5400928](#)
- Low Air Supervisory Pressure Switch [Potter Electric Bulletin 5401564](#)
- Model LP Actuator [Reliable Technical Bulletin 505](#)
- Model B-1 Accelerator [Reliable Technical Bulletin 323](#)
- Air Compressor [Reliable Technical Bulletin 256](#) (or)
[General Air](#)
- Pressure Maintenance Device [Reliable Technical Bulletin 251](#)

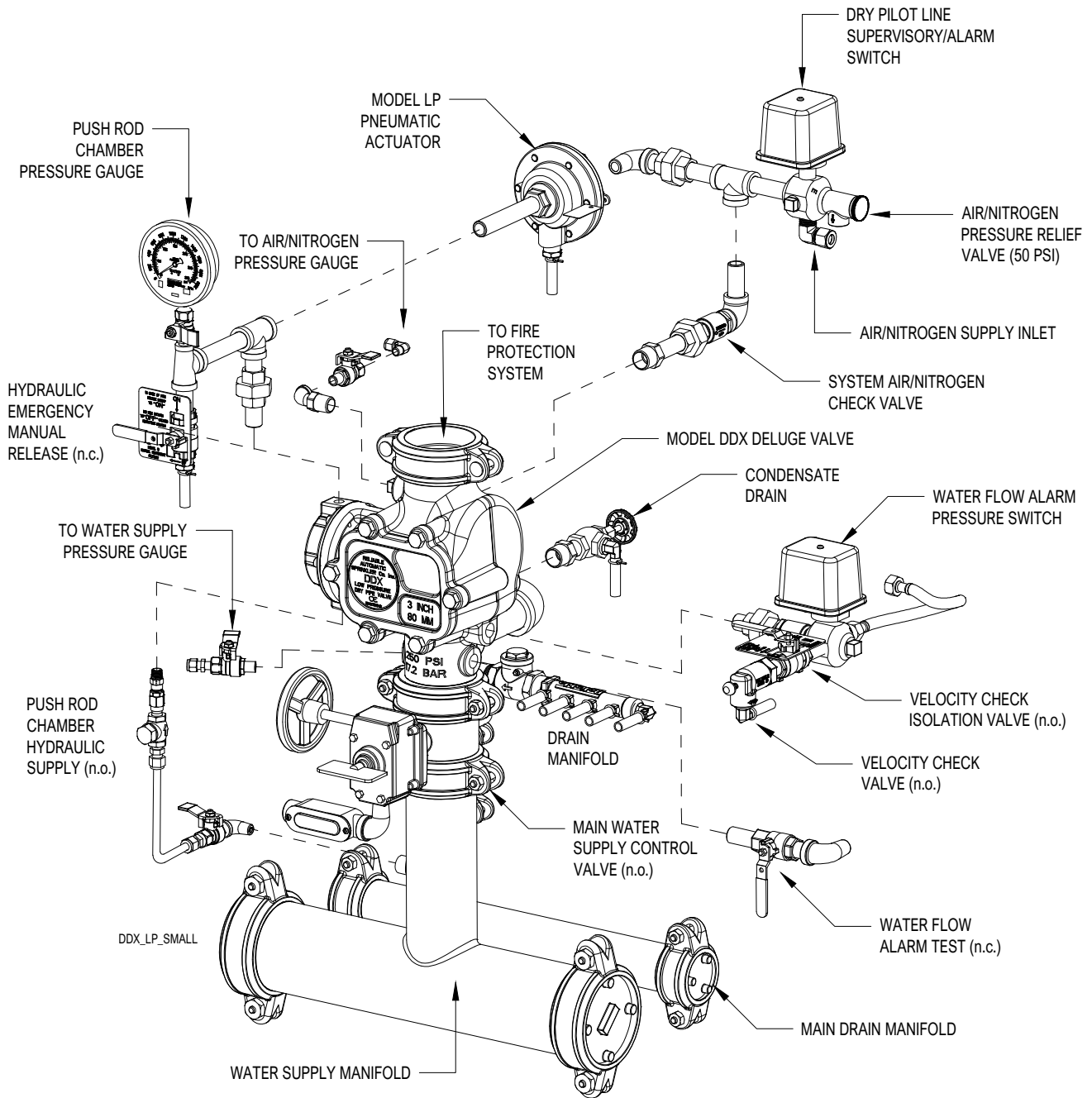

NOTES:

1. ALL COMPONENTS AND OPTIONS MAY NOT BE SHOWN.
2. DIAGRAM IS FOR REFERENCE ONLY AND MAY NOT REFLECT EXACT PRODUCT CONFIGURATION.
3. FULL ASSEMBLY DRAWINGS ARE AVAILABLE AT www.reliablesprinkler.com.

Product: Model DDX Deluge System, Wet Pilot Line Detection

The Reliable Model DDX deluge system with wet pilot trim is a mechanical release system that incorporates a hydraulic pilot (detection) line directly connected to the deluge valve releasing trim.

The activation of a thermal detector or manual release on the wet pilot detection line directly relieves hydraulic pressure on the deluge valve releasing trim, releasing water into the system, and initiating a water flow alarm.

Deluge systems utilize open sprinklers, nozzles, or other discharge devices. As such, deluge systems do not utilize compressed air or nitrogen in the piping network.

Please note that wet pilot line detection systems are limited in height and length as related to the available water supply (see below).

Reference Publications

- Model DDX PrePaK Basic Information [Reliable Technical Bulletin 760](#)
- Model DDX Deluge Valve [Reliable Technical Bulletin 519](#)
- Water Flow Alarm Pressure Switch [Potter Electric Bulletin 5400928](#)
- F1-FTR Pilot Line Detector [Reliable Technical Bulletin 180](#)

Wet Pilot Line Height vs. Length

Figure 6

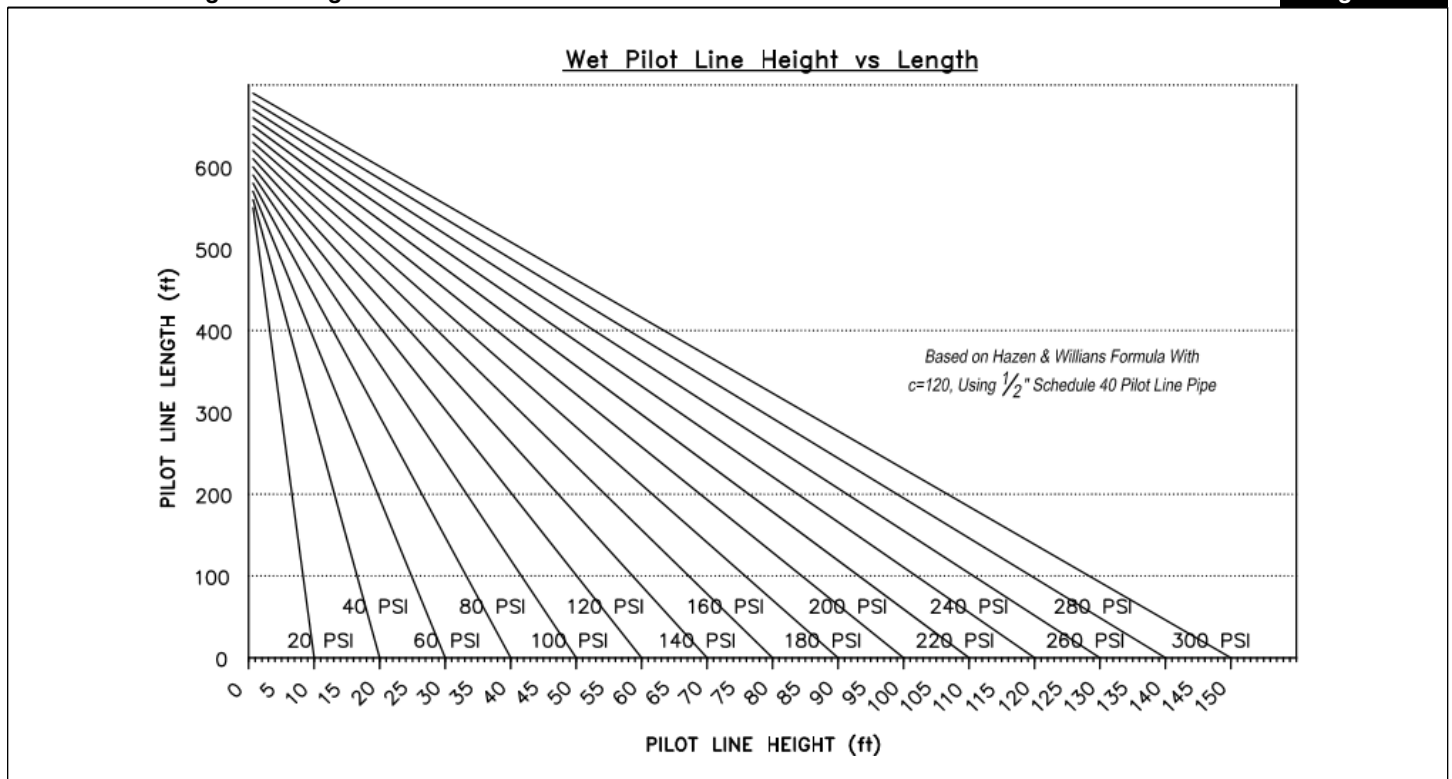

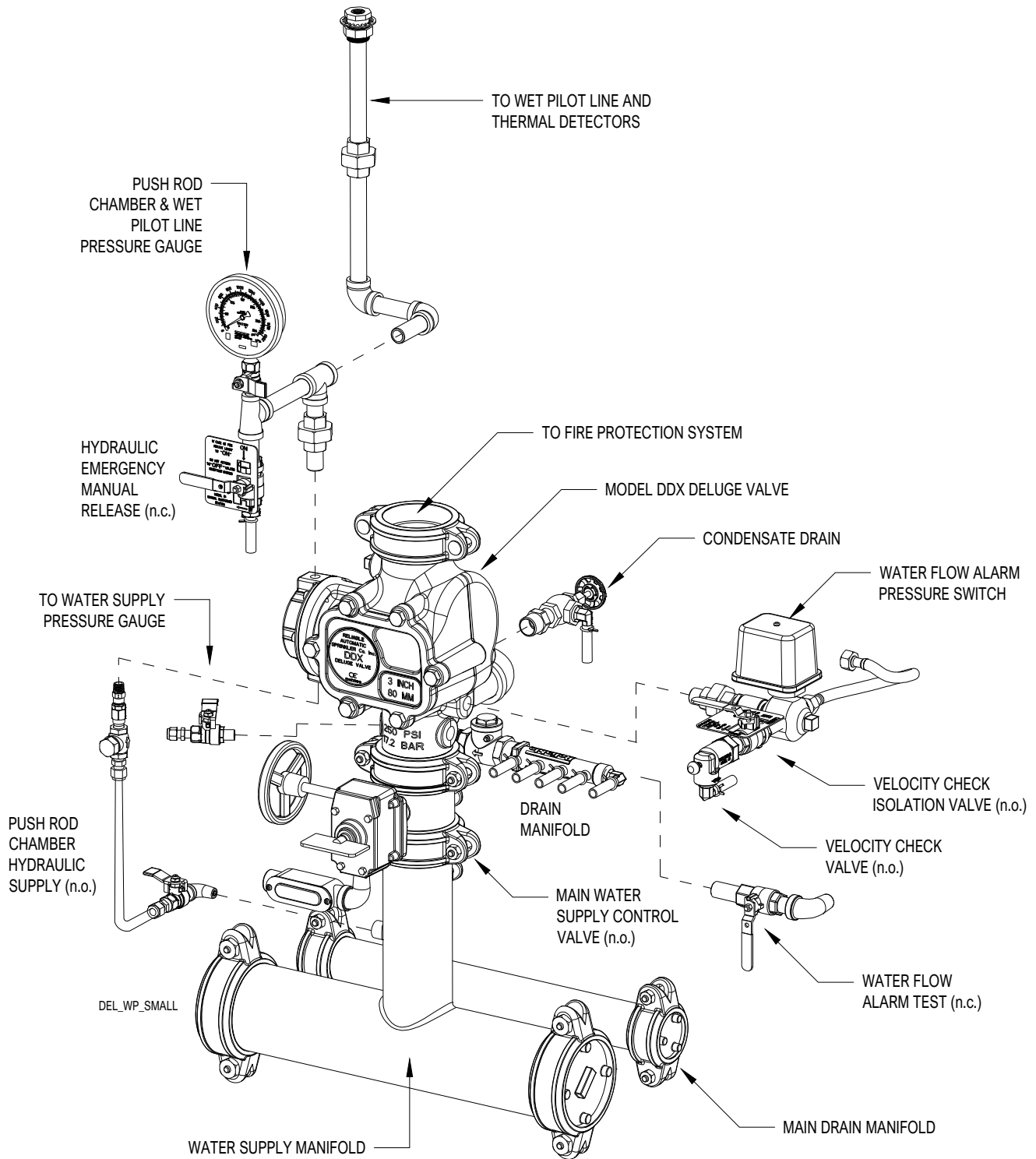

NOTES:

1. ALL COMPONENTS AND OPTIONS MAY NOT BE SHOWN.
2. DIAGRAM IS FOR REFERENCE ONLY AND MAY NOT REFLECT EXACT PRODUCT CONFIGURATION.
3. FULL ASSEMBLY DRAWINGS ARE AVAILABLE AT www.reliablesprinkler.com.

Product: Model DDX Deluge System, Dry Pilot Line Detection

The Reliable Model DDX deluge system with dry pilot trim is a mechanical release system that incorporates a pneumatic pilot (detection) line connected to the deluge valve releasing trim. The Model LP dry pilot actuator serves to separate the dry pilot piping from the hydraulic pressure in the deluge valve releasing trim.

The Model LP dry pilot actuator is diaphragm operated valve that is normally held closed using the air or nitrogen pressure. Loss of pneumatic pressure in the pilot line (presumed due to a thermal detector or manual release operating) results in the operation of the dry pilot actuator. Operation of the actuator relieves hydraulic pressure on the deluge valve releasing trim, releasing water into the system, and initiating a water flow alarm.

In the event of a slow loss of pneumatic pressure (such as a leak) on the dry pilot line, the pressure switch will operate, and a supervisory signal will report to the fire alarm system. Failure to respond to a low-pressure condition may result in operation of the deluge system.

Deluge systems utilize open sprinklers, nozzles, or other discharge devices. As such, deluge systems do not utilize compressed air or nitrogen in the piping network, however, compressed air or nitrogen is required for the dry pilot line.

Reference Publications

- Model DDX PrePaK Basic Information [Reliable Technical Bulletin 760](#)
- Model DDX Deluge Valve [Reliable Technical Bulletin 519](#)
- Water Flow Alarm Pressure Switch [Potter Electric Bulletin 5400928](#)
- Low Air Supervisory Pressure Switch [Potter Electric Bulletin 5401564](#)
- Model LP Actuator [Reliable Technical Bulletin 505](#)
- Air Compressor [Reliable Technical Bulletin 256](#) (or)
[General Air](#)
- Pressure Maintenance Device [Reliable Technical Bulletin 251](#)
- F1-FTR Pilot Line Detector [Reliable Technical Bulletin 180](#)

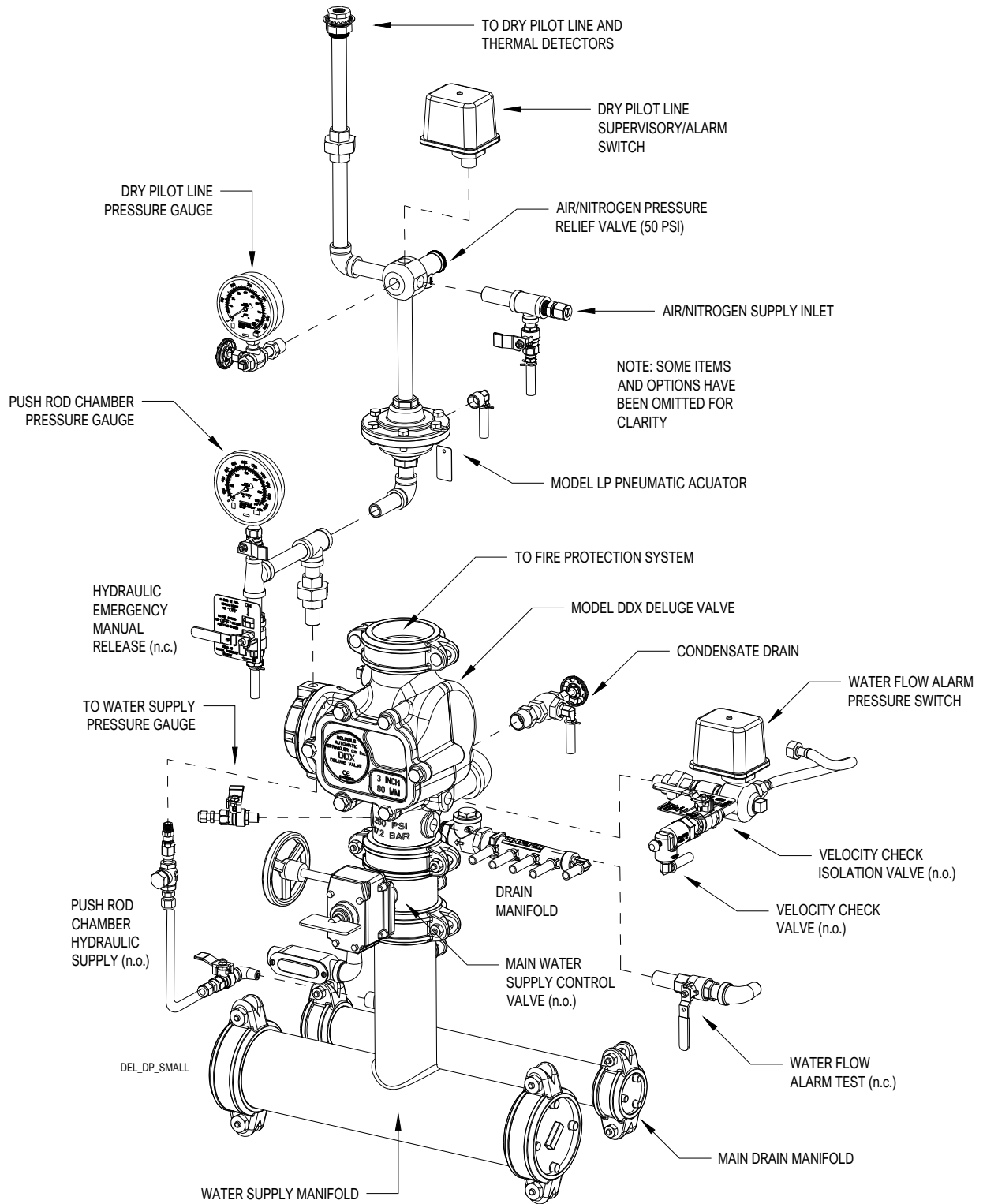

NOTES:

1. ALL COMPONENTS AND OPTIONS MAY NOT BE SHOWN.
2. DIAGRAM IS FOR REFERENCE ONLY AND MAY NOT REFLECT EXACT PRODUCT CONFIGURATION.
3. FULL ASSEMBLY DRAWINGS ARE AVAILABLE AT www.reliablesprinkler.com.

Product: Model DDX Deluge System, Electric Detection

The Reliable Model DDX deluge system with electric trim is an electric release system that incorporates a 24VDC normally closed solenoid valve on the releasing trim. The solenoid valve is energized by a listed release control panel and detection system when the appropriate type and number of events have occurred to satisfy the panel program.

The activation of a supplemental electric detection system, either on a single zone or two zones (cross zoned) will energize the solenoid, releasing water into the system and initiating a water flow alarm.

Deluge systems utilize open sprinklers, nozzles, or other discharge devices. As such, deluge systems do not utilize compressed air or nitrogen in the piping network.

Reference Publications

- Model DDX PrePaK Basic Information [Reliable Technical Bulletin 760](#)
- Model DDX Deluge Valve [Reliable Technical Bulletin 519](#)
- Water Flow Alarm Pressure Switch [Potter Electric Bulletin 5400928](#)
- Release Control Disable Switch [Potter Electric Bulletin 5401214](#)
- Solenoid Valve [Reliable Technical Bulletin 718](#)
- Air Compressor [Reliable Technical Bulletin 256](#) (or)
[General Air](#)
- Release Control Panel [Potter Electric Bulletin 5403751](#)

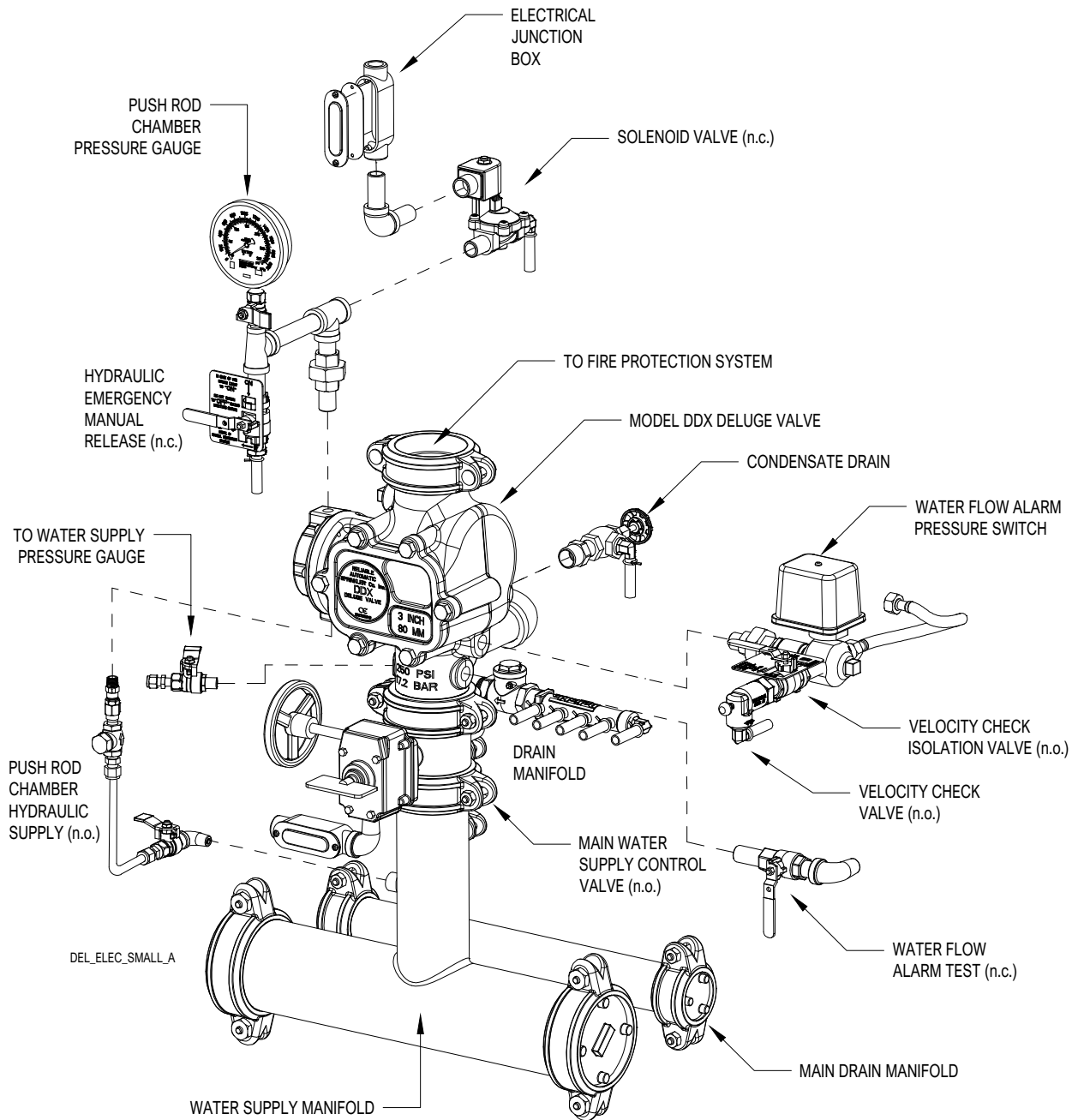

NOTES:

1. ALL COMPONENTS AND OPTIONS MAY NOT BE SHOWN.
2. DIAGRAM IS FOR REFERENCE ONLY AND MAY NOT REFLECT EXACT PRODUCT CONFIGURATION.
3. FULL ASSEMBLY DRAWINGS ARE AVAILABLE AT www.reliablesprinkler.com.

Product: Model DDX Single Interlock Preaction System, Dry Pilot Line Detection

The Reliable Model DDX single interlock preaction system with dry pilot trim is a mechanical release system that incorporates a pneumatic pilot (detection) line connected to the deluge valve releasing trim. The Model LP dry pilot actuator serves to separate the dry pilot piping from the hydraulic pressure in the deluge valve releasing trim. This system does not incorporate an electric detection and release system.

The Model LP dry pilot actuator is diaphragm operated valve that is normally held closed using the air or nitrogen pressure. Loss of pneumatic pressure in the pilot line (presumed due to a thermal detector or manual release operating) results in the operation of the dry pilot actuator. Operation of the actuator relieves hydraulic pressure on the deluge valve releasing trim, releasing water into the system, and initiating a water flow alarm.

In the event of a slow loss of pneumatic pressure (such as a leak) on the dry pilot line, the pressure switch will operate, and a supervisory signal will report to the fire alarm system. Failure to address a low-pressure condition may result in operation of the deluge system.

Single interlock systems utilize closed discharge devices, and the system is supervised for integrity using pneumatic pressure. In the event of a slow loss of pneumatic pressure (such as a leak) on the system, the pressure switch will operate, and a supervisory signal will report to the fire alarm system, however, water will not be released into the system. Failure to address a low-pressure condition may result in unwanted discharge of water should the deluge valve subsequently operate due to a detection event.

Reference Publications

- Model DDX PrePaK Basic Information [Reliable Technical Bulletin 760](#)
- Model DDX Deluge Valve [Reliable Technical Bulletin 519](#)
- Water Flow Alarm Pressure Switch [Potter Electric Bulletin 5400928](#)
- Low Air Supervisory Pressure Switch [Potter Electric Bulletin 5400928](#)
- Model LP Actuator [Reliable Technical Bulletin 505](#)
- Air Compressor [Reliable Technical Bulletin 256](#) (or)
[General Air](#)
- Pressure Maintenance Device [Reliable Technical Bulletin 251](#)
- F1-FTR Pilot Line Detector [Reliable Technical Bulletin 180](#)

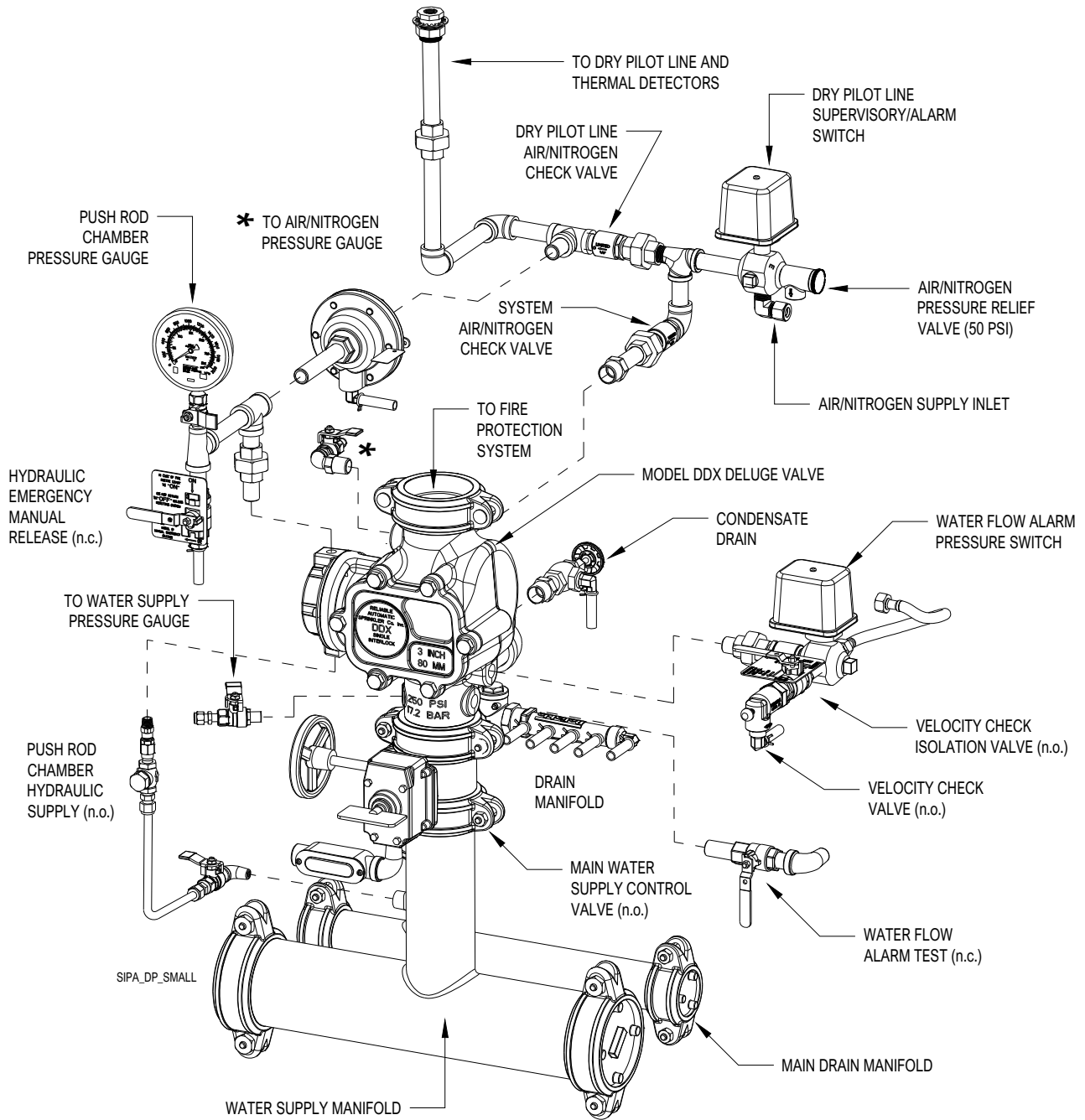

NOTES:

1. ALL COMPONENTS AND OPTIONS MAY NOT BE SHOWN.
2. DIAGRAM IS FOR REFERENCE ONLY AND MAY NOT REFLECT EXACT PRODUCT CONFIGURATION.
3. FULL ASSEMBLY DRAWINGS ARE AVAILABLE AT www.reliablesprinkler.com.

Product: Model DDX Single Interlock Preaction System, Wet Pilot Line Detection

The Reliable Model DDX single interlock preaction system with wet pilot trim is a mechanical release system that incorporates a hydraulic pilot (detection) line directly connected to the deluge valve releasing trim.

The activation of a thermal detector or manual release on the wet pilot detection line directly relieves hydraulic pressure on the deluge valve releasing trim, releasing water into the system and initiating a water flow alarm.

Single interlock systems utilize closed discharge devices, and the system is supervised for integrity using pneumatic pressure. In the event of a slow loss of pneumatic pressure (such as a leak) on the system, the pressure switch will operate, and a supervisory signal will report to the fire alarm system, however, water will not be released into the system. Failure to respond to a low-pressure condition may result in unwanted discharge of water should the deluge valve subsequently operate due to a detection event.

Please note that wet pilot line detection systems are limited in height and length as related to the available water supply (please refer to Figure 6 on page 10).

Reference Publications

- Model DDX PrePaK Basic Information [Reliable Technical Bulletin 760](#)
- Model DDX Deluge Valve [Reliable Technical Bulletin 519](#)
- Water Flow Alarm Pressure Switch [Potter Electric Bulletin 5400928](#)
- F1-FTR Pilot Line Detector [Reliable Technical Bulletin 180](#)

Wet Pilot Line Height vs. Length

Figure 11

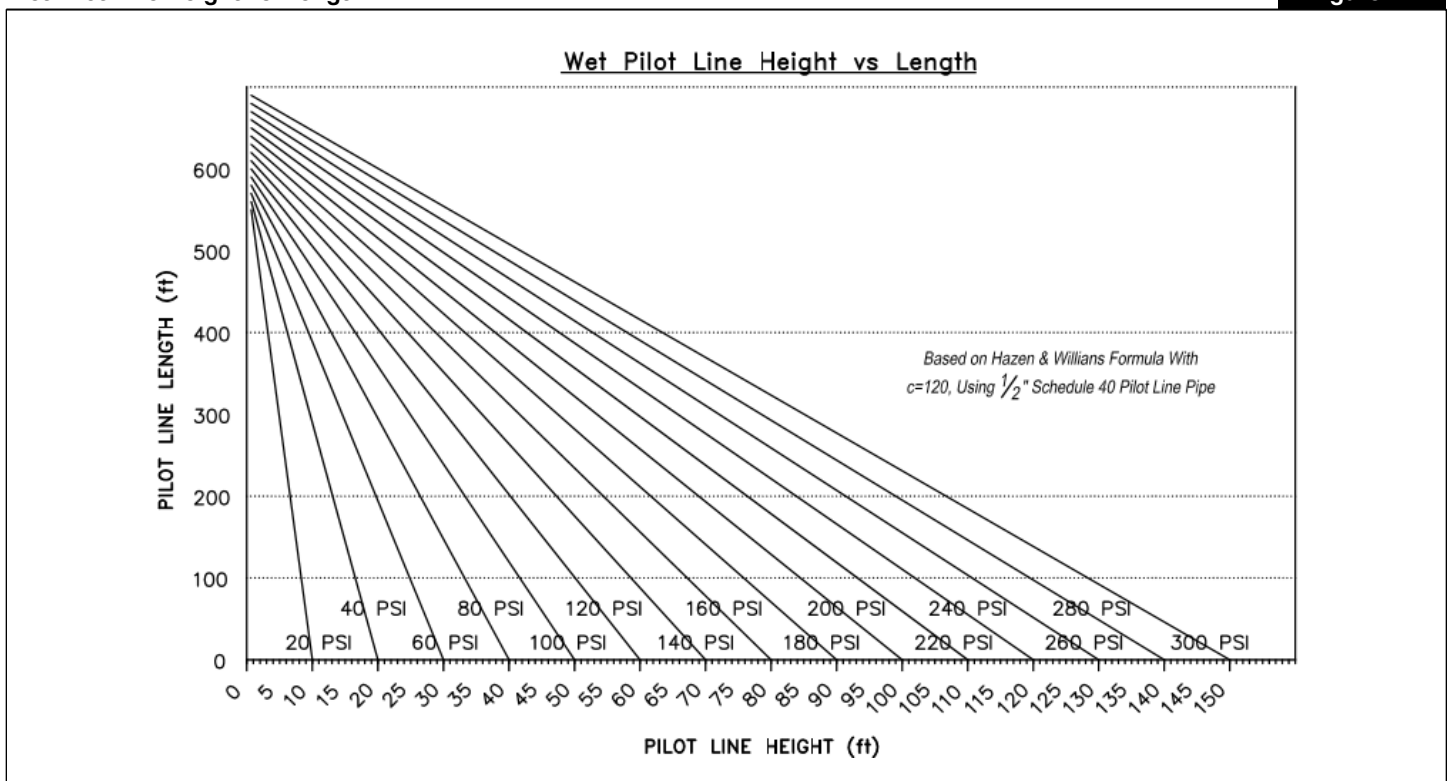

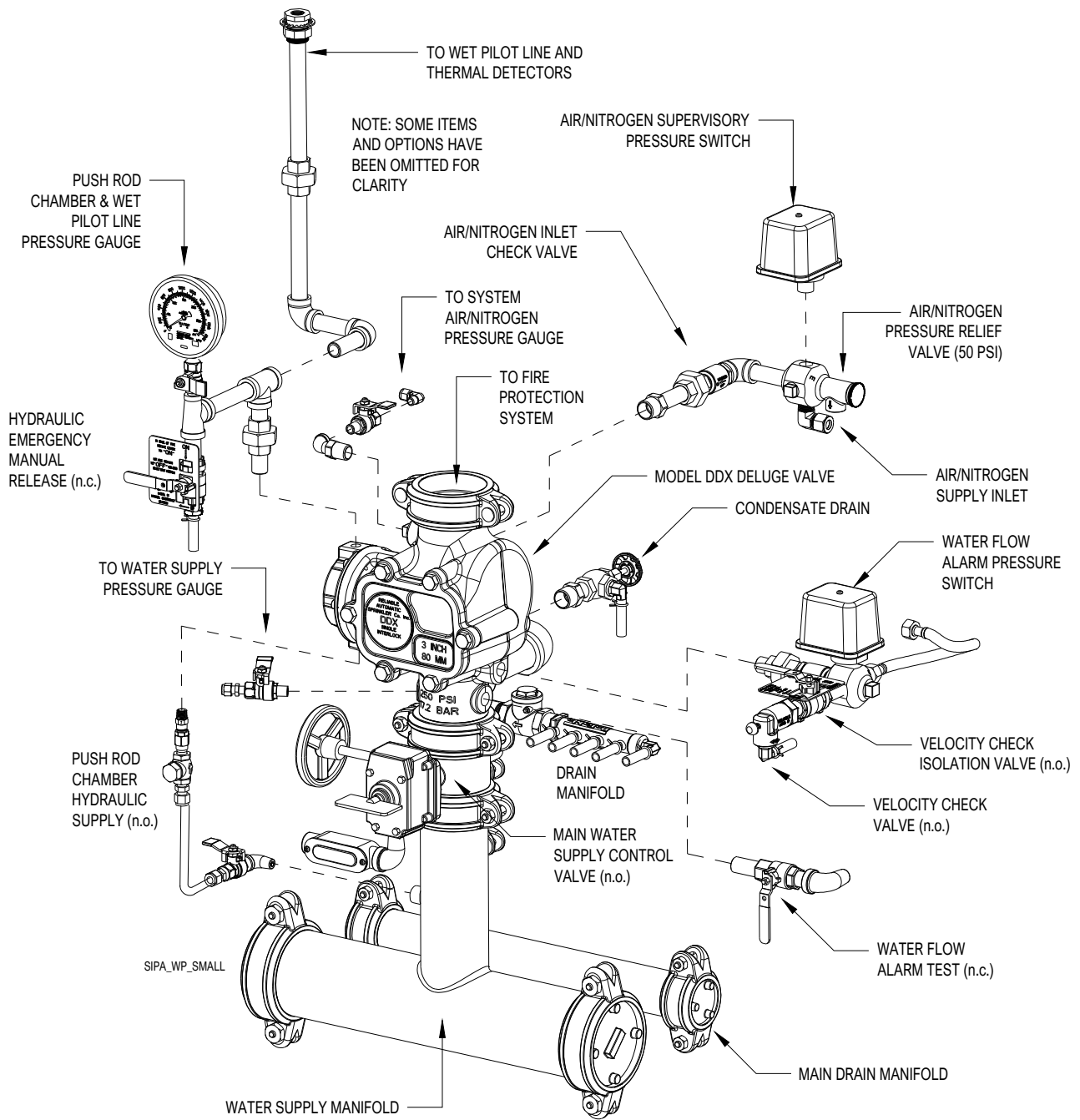

NOTES:

1. ALL COMPONENTS AND OPTIONS MAY NOT BE SHOWN.
2. DIAGRAM IS FOR REFERENCE ONLY AND MAY NOT REFLECT EXACT PRODUCT CONFIGURATION.
3. FULL ASSEMBLY DRAWINGS ARE AVAILABLE AT www.reliablesprinkler.com.

Product: Model DDX Type PL Double Interlock Preaction System

The Reliable Model DDX Type PL double interlock preaction system is a mechanical release system that incorporates a dual-chamber low-pressure dry pilot actuator on the deluge valve releasing trim. Both chambers of the dry pilot actuator must depressurize for the device to operate. The Model PL dry pilot actuator serves to separate the dry pilot piping and system piping from the hydraulic pressure in the deluge valve releasing trim.

Sudden loss of pneumatic pressure on the dry pilot line (presumed due to operation of a thermal detector or manual station) will report to the fire alarm system, however, water will not be released into the system. Subsequent loss of pneumatic pressure on the system (presumed due to a fire sprinkler opening) will operate the Model PL dry pilot actuator, releasing water into the system and initiating a water flow alarm.

In the event of pneumatic pressure loss on the system and normal dry pilot line pressure, the system pressure switch will operate and report to the fire alarm system, however, water will not be released into the system. Failure to address a system low-pressure condition may result in unwanted discharge of water should the deluge valve subsequently operate due to a detection event.

In the event of pneumatic pressure loss on the dry pilot line and normal system pressure, the dry pilot line pressure switch will operate and report to the fire alarm system, however, water will not be released into the system. Failure to respond to a dry pilot line low-pressure condition may result in operation of the deluge valve should the system experience a sudden loss of pressure.

Reference Publications

- Model DDX PrePaK Basic Information [Reliable Technical Bulletin 760](#)
- Model DDX Deluge Valve [Reliable Technical Bulletin 519](#)
- Model DDX Type PL Preaction System [Reliable Technical Bulletin 752](#)
- Water Flow Alarm Pressure Switch [Potter Electric Bulletin 5400928](#)
- Low Air Supervisory Pressure Switch [Potter Electric Bulletin 5401564](#)
- Model PL Actuator [Reliable Technical Bulletin 752](#)
- Model B-1 Accelerator [Reliable Technical Bulletin 180](#)
- Air Compressor [Reliable Technical Bulletin 256](#) (or)
[General Air](#)
- Pressure Maintenance Device [Reliable Technical Bulletin 251](#)
- F1-FTR Pilot Line Detector [Reliable Technical Bulletin 323](#)

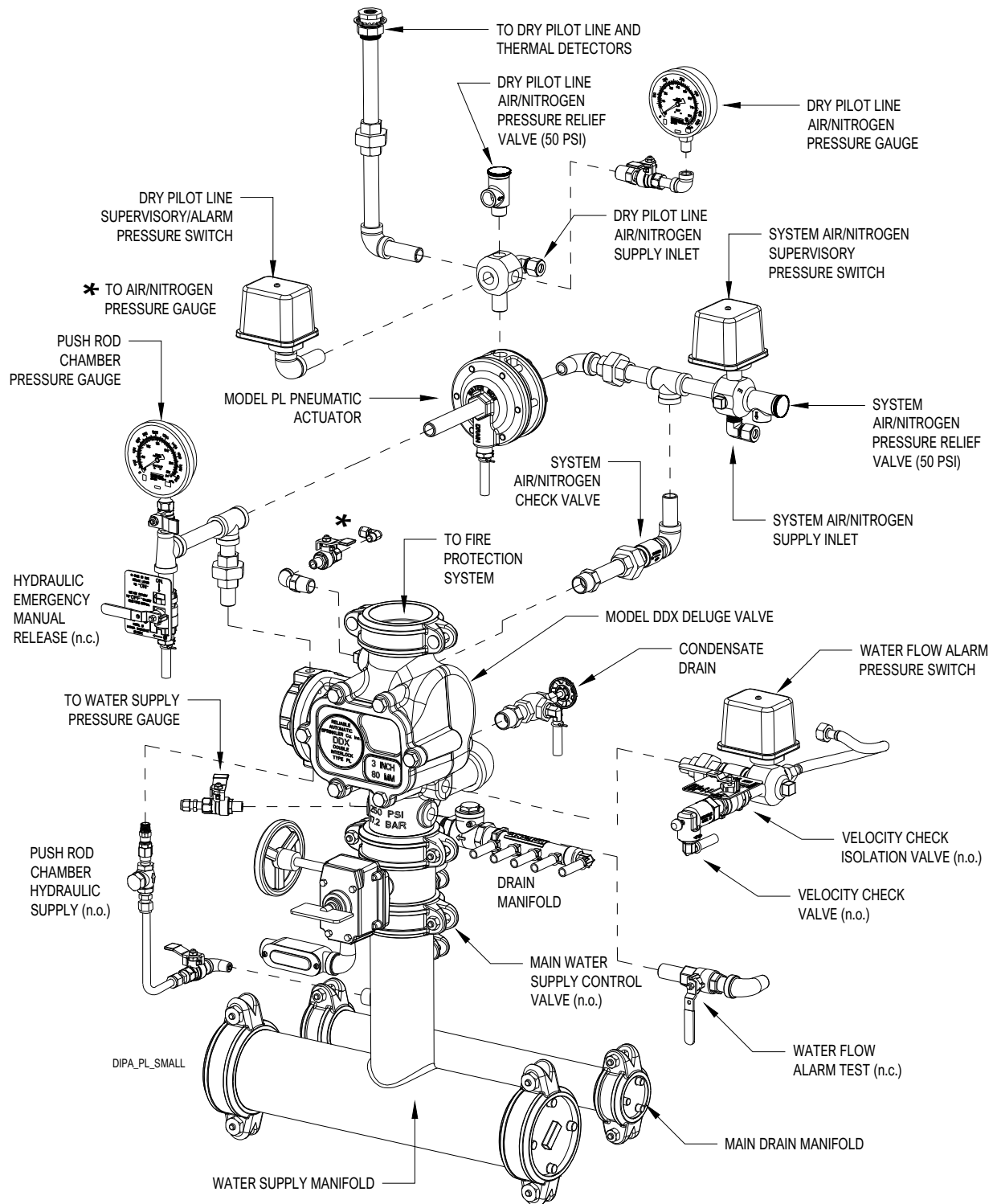

NOTES:

1. ALL COMPONENTS AND OPTIONS MAY NOT BE SHOWN.
2. DIAGRAM IS FOR REFERENCE ONLY AND MAY NOT REFLECT EXACT PRODUCT CONFIGURATION.
3. FULL ASSEMBLY DRAWINGS ARE AVAILABLE AT www.reliablesprinkler.com.

Product: Model DDX Non-Interlock Preaction System

The Reliable Model DDX Non-Interlock preaction system is a specialized system that operates independently as either an electric release single interlock system or a low pressure dry pipe system. The system incorporates a 24VDC normally closed solenoid valve and a Model LP low-pressure dry pilot actuator on the deluge valve releasing trim. The releasing devices are not in series, but rather are parallel such that opening of either device will release water into the system.

When operating as a single interlock system, activation of a supplemental electric detection system, either on a single zone or two zones (cross zoned) will energize the solenoid valve, release water into the system, and initiate a water flow alarm.

The Model LP dry pilot actuator is diaphragm operated valve that is normally held closed using the same air or nitrogen pressure contained in the dry pipe system. When operating as a low-pressure dry pipe system, loss of pneumatic pressure in the system (presumed due to a fire sprinkler operating) results in the opening of the dry pilot actuator which releases water into the system and initiates a water flow alarm.

In the event of a slow loss of pneumatic pressure (such as a leak), the pressure switch will operate, and a supervisory signal will report to the fire alarm system.

Reference Publications

- Release Control Disable Switch [Potter Electric Bulletin 5401214](#)
- Model DDX PrePaK Basic Information [Reliable Technical Bulletin 760](#)
- Model DDX Deluge Valve [Reliable Technical Bulletin 519](#)
- Model DDX Non-Interlock Preaction System [Reliable Technical Bulletin 756](#)
- Water Flow Alarm Pressure Switch [Potter Electric Bulletin 5400928](#)
- Low Air Supervisory Pressure Switch [Potter Electric Bulletin 5401564](#)
- Model LP Actuator [Reliable Technical Bulletin 505](#)
- Model B-1 Accelerator [Reliable Technical Bulletin 180](#)
- Air Compressor [Reliable Technical Bulletin 256](#) (or)
[General Air](#)
- Pressure Maintenance Device [Reliable Technical Bulletin 251](#)
- Release Control Panel [Potter Electric Bulletin 5403751](#)

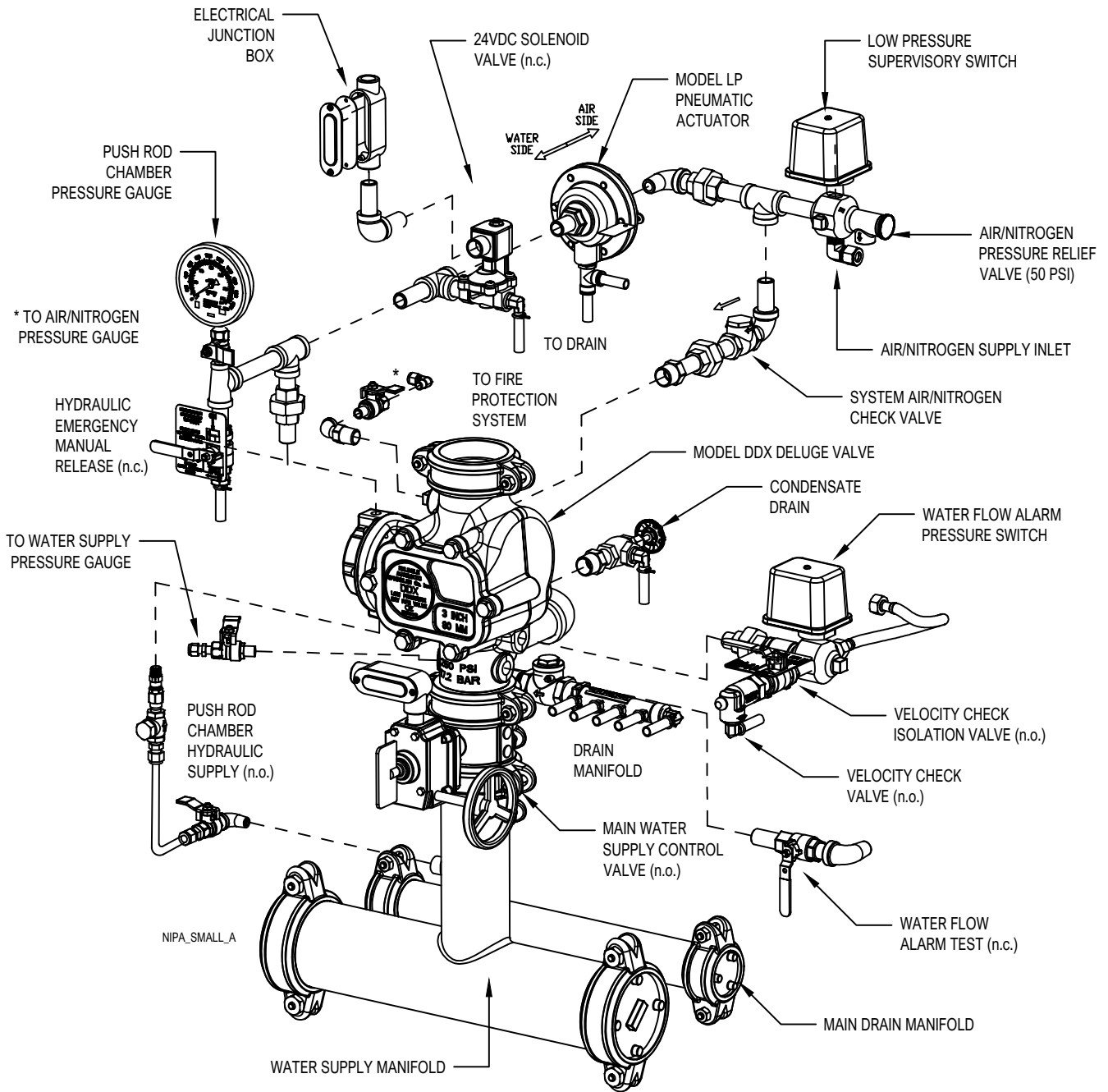

NOTES:

1. ALL COMPONENTS AND OPTIONS MAY NOT BE SHOWN.
2. DIAGRAM IS FOR REFERENCE ONLY AND MAY NOT REFLECT EXACT PRODUCT CONFIGURATION.
3. FULL ASSEMBLY DRAWINGS ARE AVAILABLE AT www.reliablesprinkler.com.

4. Placement & Anchoring

The Reliable PrePaK™ and all interconnected wet piping must be in a readily accessible location that is maintained at a minimum temperature of 40°F (4°C). Heat tracing is not permitted as an alternative to locating the unit in a conditioned space.

Position the PrePaK™ on a hard surface such that full 180° opening of the main door is provided for access. The units are also provided with access panels on each side. For service and maintenance purposes, consideration should be given to keeping the sides clear for access.

Where required, the unit can be anchored to the floor using the holes provided. Alternate methods of anchoring the PrePaK™ are acceptable when approved by the authority having jurisdiction.

Optional Seismic Kit: Reliable part number 6501200041 (25" x 28" cabinet for 2" -4" systems without nitrogen generator) and part number 6501200042 (30" x 33" cabinet for 6" and 8" systems and ALL units with nitrogen generator) are seismic upgrade kits required to make the Reliable PrePaK compliant with OSHPD Special Seismic Certification Preapproval (SDS(g) = 2.5 and z/h = 1). One kit is required for each PrePaK™; please reference Reliable Caution Sheet 331 for full details.

5. Piping Connections (Refer to Figures 1 & 2)

Verify compatibility of the water supply with the Model DDX valve materials prior to installation. Three pipe connections (possibly four if units are side by side) are required for each unit:

- Water supply—Lower front side (right or left) of unit
- Drain—Lower rear side (right or left) of unit
- System—Top of unit

Where necessary for the water supply and drain, reverse the outlet access panel (with rubber grommets) and the solid access panel.

Note that the manifold size supplying the system may not match the system size. It is the customer's responsibility to confirm the size of the system supply pipe and provide appropriate transition fittings if necessary.

The drain should be routed to a safe discharge either outside of the building or other location acceptable to the owner and/or authority having jurisdiction. Closed drain systems must be capable of handling the discharge of a fully opened main drain valve under full system pressure.

6. Power Supply Connections

For convenience, separate Type SO power cables are provided for the release control panel, air compressor, and nitrogen generator, where so equipped. These cables are extended through the floor of the unit for field connection to an approved permanent power source. A separate circuit is required for each device.

When required by a local electrical code or other authority having jurisdiction, these cables may be removed to the point of connection on the appropriate device and replaced with approved wiring. Replacement of SO power cords with other approved power wiring does not affect listing or warranty of the product.

7. Factory Wiring

Based upon the type of system and options selected, some or all the following electrical devices are factory-wired to a watertight terminal box mounted on the interior of the enclosure:

- Potter Electric PFC-4410G3 Releasing Control Panel
- Main Water Control Valve Tamper Switch
- System Side Water Control Valve Tamper Switch
- Pneumatic Pressure Supervisory Switch
- Water Flow Pressure Alarm Switch
- Normally Closed 24VDC Solenoid Valve
- Release Control (Solenoid) Disable Switch
- Solenoid Release Manual Pull Station
- CoilKeeper™ Solenoid Coil Supervisory Switch
- Nitrogen Generator Controls

When ordered with the Potter PFC-4410 Releasing Control Panel, the power supply, standby batteries, battery charger, and rectifier circuitry are all contained within the panel. Batteries that provide 90 hours of standby power are provided with the panel. For additional information on the releasing panel, please refer to Potter Manual #5403751 (Installation, Operation, and Instruction Manual for the PFC-4410G3 Releasing Control Panel). A copy of that document is provided with each unit so equipped.

See Figures 15 through 19 for location and factory electrical connections of these devices.

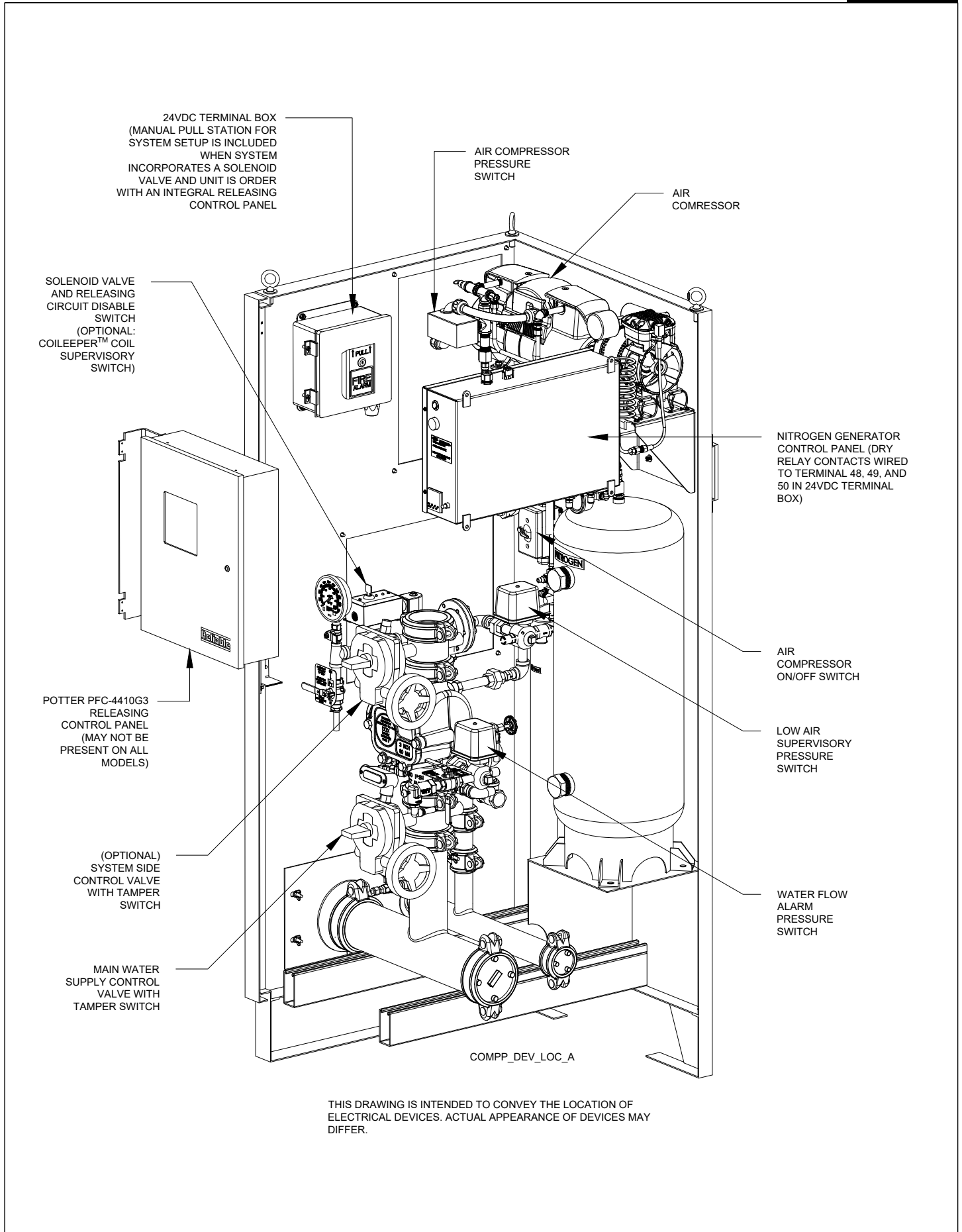

THIS DRAWING IS INTENDED TO CONVEY THE LOCATION OF ELECTRICAL DEVICES. ACTUAL APPEARANCE OF DEVICES MAY DIFFER.

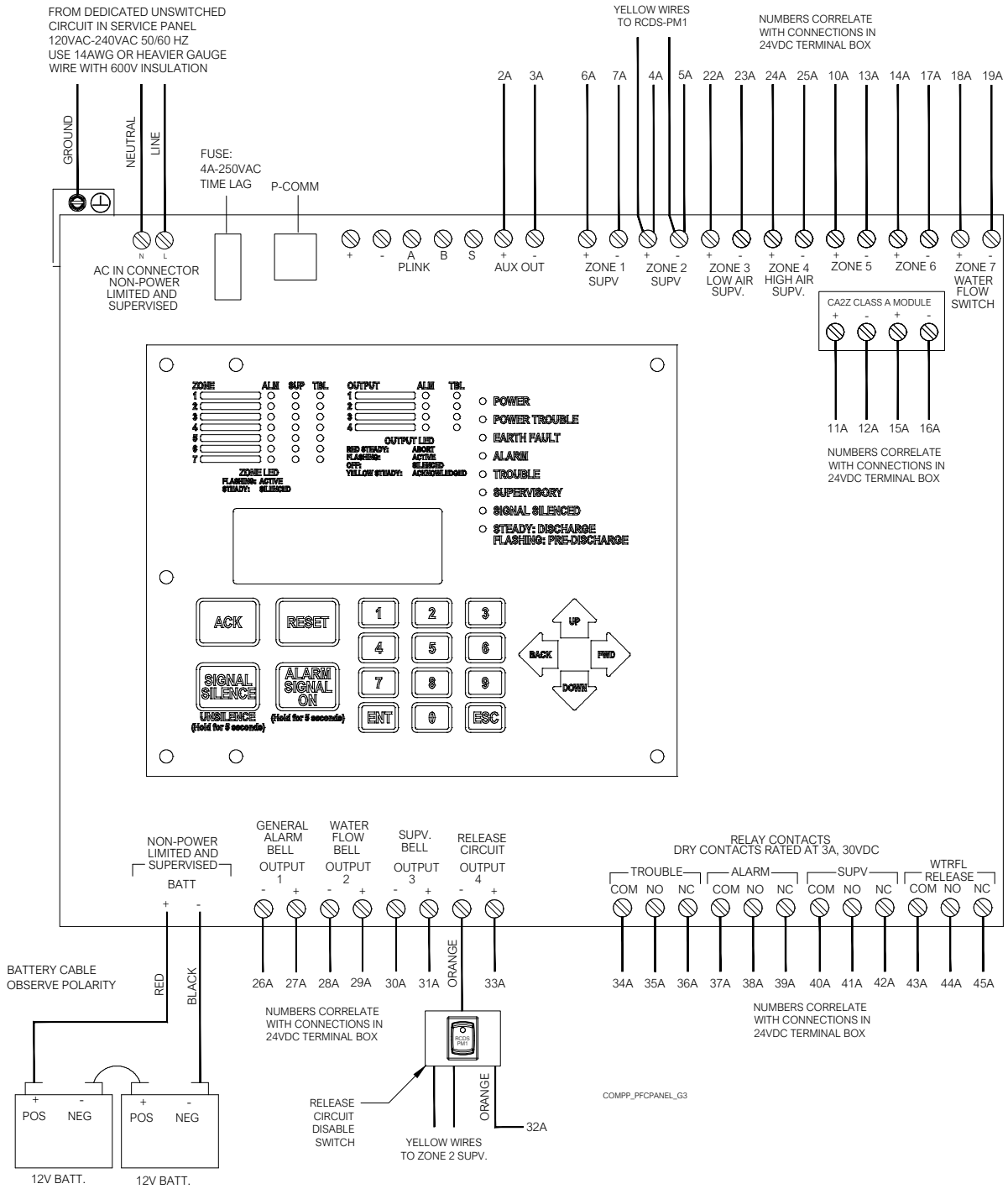

POTTER PFC-4410G3 RELEASING CONTROL PANEL

Notes:

1. Panel is factory wired and mapped to 24VDC terminal box inside enclosure. All field wiring terminates in 24VDC terminal box; no field connections are required inside the Potter PFC4410-RC panel.
2. Leave end-of-line resistors (EOLR) on all unused circuits.
3. Polarity marked on outputs 1 through 4 are for an activated (non-normal) condition. Polarity is reversed in normal condition.
4. Maximum current per individual output is 1 amp.
5. Maximum current for all outputs combined is 2.5 amps.
6. All initiating and release circuits are supervised and power limited.

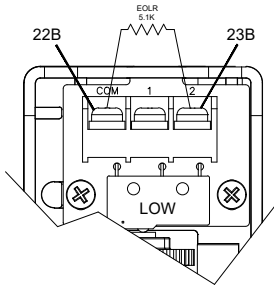

LOW AIR SUPERVISORY PRESSURE SWITCH
WIRED TO ZONE #3 IN RELEASING CONTROL PANEL WHEN SO EQUIPPED

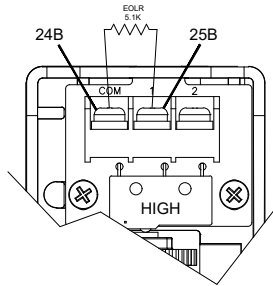

HIGH AIR SUPERVISORY PRESSURE SWITCH
WIRED TO ZONE #4 IN RELEASING CONTROL PANEL WHEN SO EQUIPPED

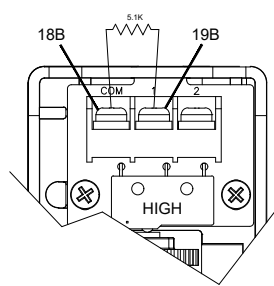

WATER FLOW ALARM PRESSURE SWITCH
WIRED TO ZONE #7 IN RELEASING CONTROL PANEL WHEN SO EQUIPPED

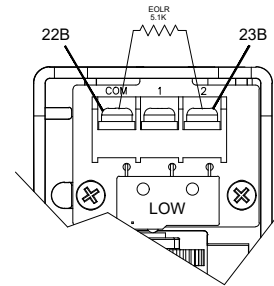

LOW NITROGEN CYLINDER PRESSURE SWITCH
WIRED TO ZONE #3 IN RELEASING CONTROL PANEL WHEN SO EQUIPPED

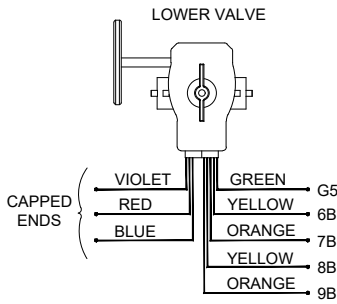

SINGLE CONTROL VALVE 2" THROUGH 8"
WIRED TO SUPV #1 IN RELEASING CONTROL PANEL WHEN SO EQUIPPED

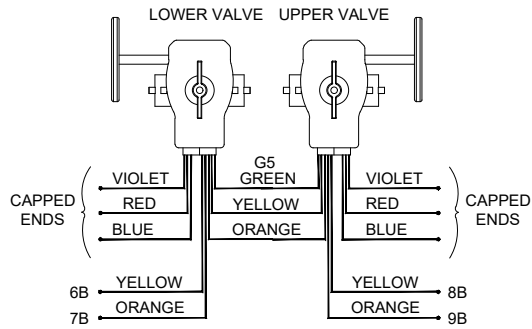

DOUBLE CONTROL VALVE 2" THROUGH 8"
WIRED TO SUPV #1 IN RELEASING CONTROL PANEL WHEN SO EQUIPPED

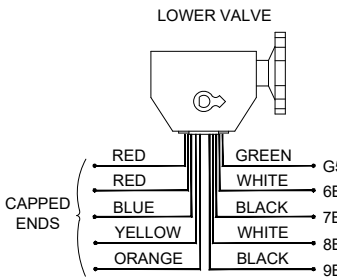

SINGLE CONTROL VALVE (ALTERNATE 2" REL-BVG)
WIRED TO SUPV #1 IN RELEASING CONTROL PANEL WHEN SO EQUIPPED

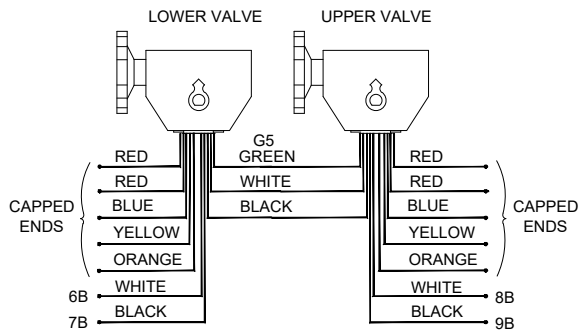

DOUBLE CONTROL VALVE (ALTERNATE 2" REL-BVG)
WIRED TO SUPV #1 IN RELEASING CONTROL PANEL WHEN SO EQUIPPED

NOTE: NUMBERS ON WIRES CORRELATE TO TERMINAL NUMBERS IN 24VDC TERMINAL BOX
COMP_WIRE_DEV1

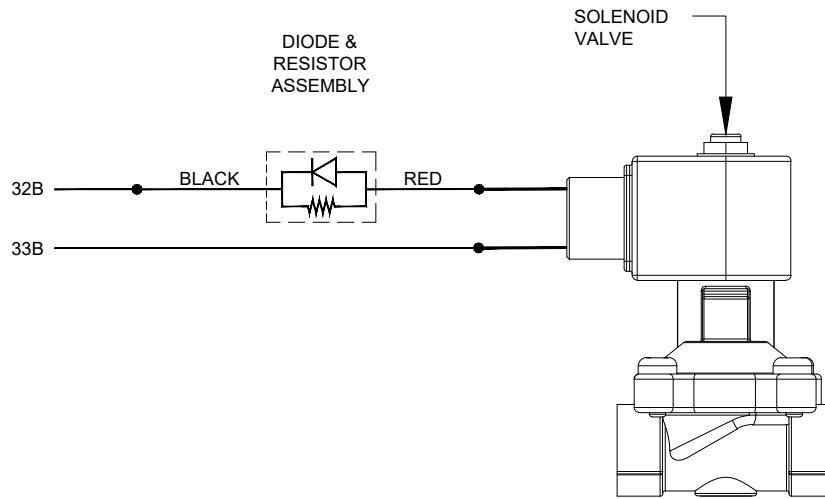

SOLENOID VALVE

NOTE: NUMBERS ON WIRES CORRELATE TO TERMINAL NUMBERS IN 24VDC TERMINAL BOX

COMPP_WIRE_DEV2_A

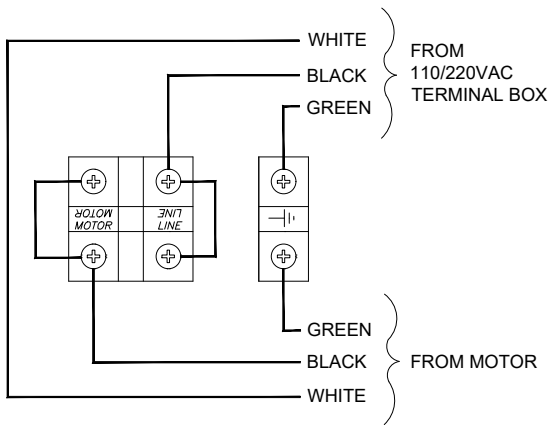

**AIR COMPRESSOR POWER WIRING
(110 VAC)**

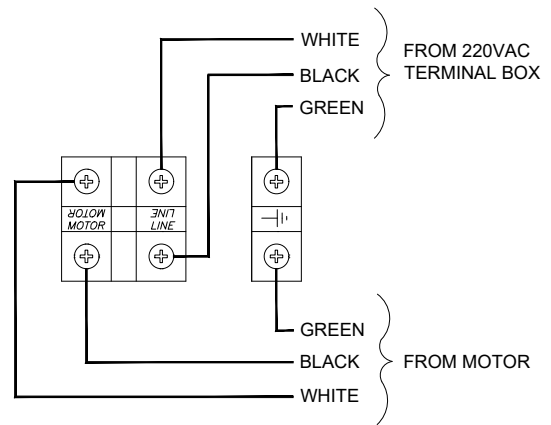

**AIR COMPRESSOR POWER WIRING
(220 VAC)**

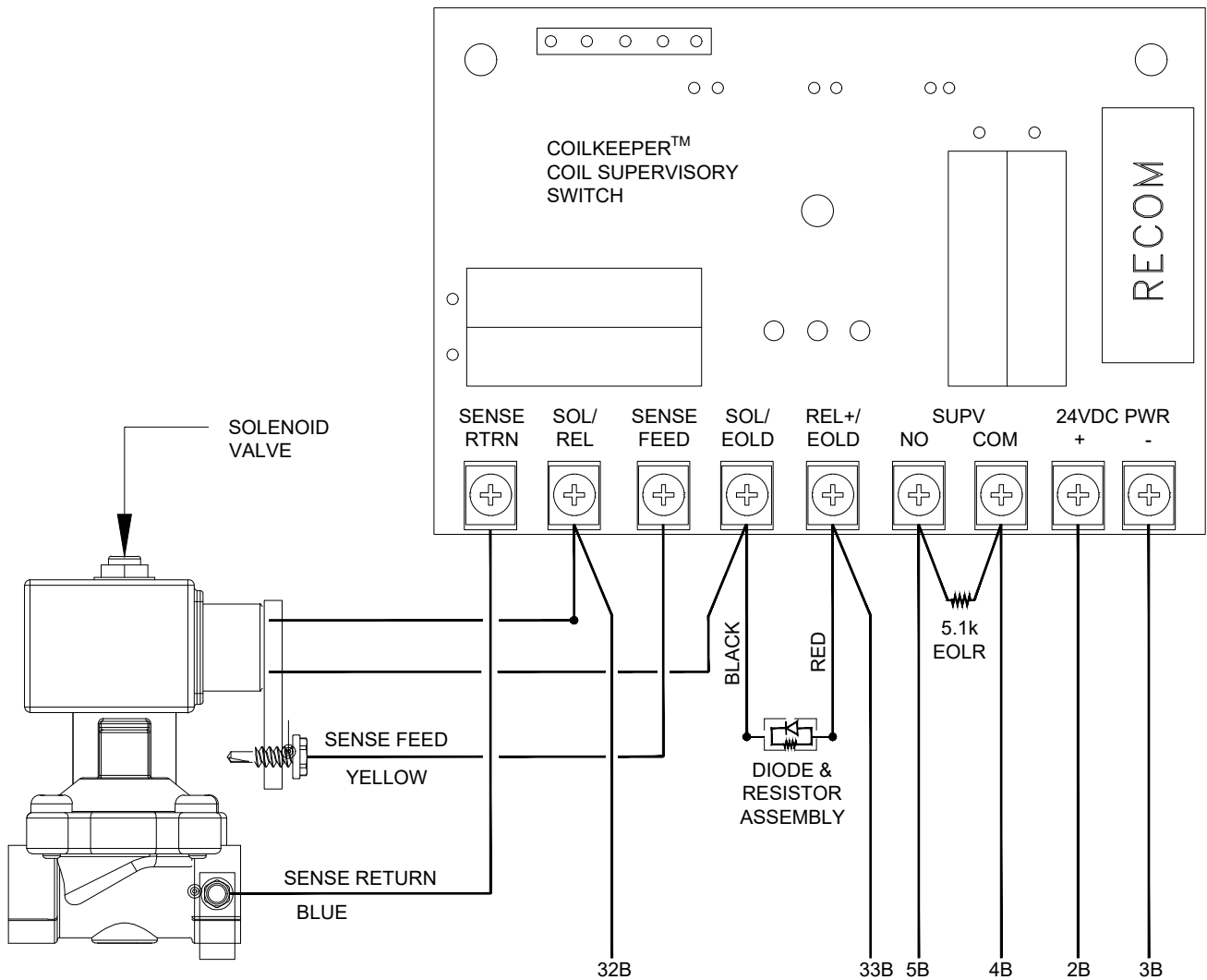

SOLENOID VALVE AND OPTIONAL COILKEEPER™ COIL SUPERVISORY SWITCH (CSS)

WIRED TO SUPERVISORY #2 IN RELEASING CONTROL PANEL WHEN SO EQUIPPED

NOTE: NUMBERS ON WIRES CORRELATE TO TERMINAL NUMBERS IN 24VDC TERMINAL BOX

COMPP_WIRE_DEV3_A

8. Field Wiring: Units with Releasing Control Panel

This section provides basic information regarding low voltage field wiring. For PrePaK™ units provided with an integral Potter PFC-4410 Releasing Control Panel, all input and output functions are factory wired (mapped) to a watertight junction box located in the interior upper left corner of the unit. All field wiring occurs within the watertight junction box. Field wiring requirements will differ depending on the type of system and whether Class B (two-wire) or Class A (four-wire) circuitry is used.

Please refer to Figures 20 through 23 on the following pages.

A. Detection

For electric release units (Type D, Type F, electric release deluge, and non-interlock), listed and approved electrical detectors must be connected to the terminal block.

Connect Class B wires for detection zone 1 on terminals 10 and 13 of the terminal strip (see Figure 20). Relocate EOL resistor currently installed between terminals 10 and 13 to the end of the detection circuit.

Connect Class A wires for detection zone 1 on terminals 10, 11, 12, and 13 of the terminal strip (see Figure 20). Remove and store the EOL resistor currently installed between terminals 10 and 13 (EOL resistor is not used on Class A circuits).

Where two zones of detection are used (cross zoning), connect Class B wires for detection zone 2 on terminals 14 and 17 (see Figure 20). Relocate EOL resistor currently installed between terminals 14 and 17 to the end of the detection circuit.

Where two zones of detection are used (cross zoning), connect Class A wires for detection zone 2 on terminals 14, 15, 16, and 17 of the terminal strip (see Figure 21). Remove and store the EOL resistor currently installed between terminals 14 and 17 (EOL resistor is not used on Class A circuits).

B. Release

For electric release units (Type D, Type F, electric release deluge, and non-interlock), all necessary release devices are factory wired and no additional field wiring is necessary.

All electric release units incorporate a Releasing Circuit Disable Switch (RCDS) to facilitate testing and maintenance of the system. This device is factory wired and no additional field wiring is necessary.

C. Local Monitoring

Control valve tamper switch(es), system pressure switch, and water flow alarm switch are factory wired no additional field wiring is necessary.

D. Notification Devices

Connection of bells, horns, horn/strobes, or other listed and approved Potter PFC-4410G3 compatible notification devices (provided by others) are made in the field using the following terminals after removing and storing the factory installed end-of-line resistors (see Figure 22). Observe polarity when connecting notification devices to the terminal block.

Output 1 General alarm: Terminals 26 and 27.

Output 2 Water flow: Terminals 28 and 29.

Output 3 Supervisory: Terminals 30 and 31.

(Special Note for NYC: When programmed for NYC compliance, the release control panel “trouble” signal is mapped to output 2. General alarm and water flow alarm are combined on output zone 1).

E. Remote Monitoring

Dry relay contacts for trouble, general alarm, supervisory, and water flow signals to the main building fire alarm system must be made in the field using the following terminals (see Figure 20).

Trouble: Terminals 34, 35, and 36 (depending on normally open or closed circuit)

General alarm: Terminals 37, 38, and 39 (depending on normally open or closed circuit)

Supervisory: Terminals 40 and 41

Water flow: Terminals 42 and 43

Nitrogen Generator alarm: Terminals 48, 49, and 50 (depending on normally open or closed circuit)

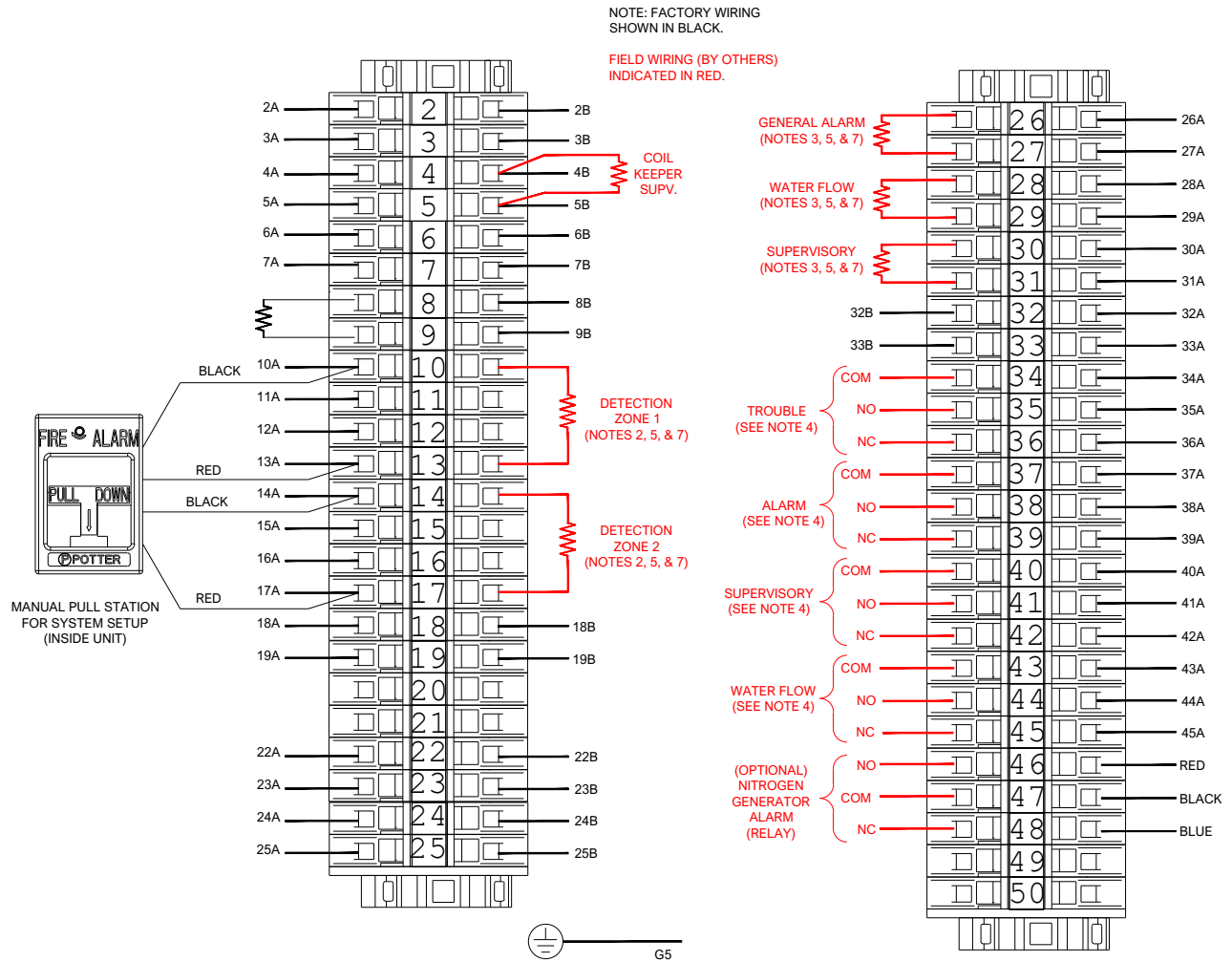

WIRING FOR UNITS WITH INTEGRAL RELEASING PANEL

COMPP_WIRE_PANEL_B

NOTES:

1. THIS DRAWING IS INTENDED AS A REFERENCE ONLY. DESIGN OF THE DETECTION, RELEASE, AND NOTIFICATION SYSTEM (BY OTHERS) MUST MEET THE MINIMUM REQUIREMENTS OF NFPA 13, NFPA 72, AND THE AUTHORITY HAVING JURISDICTION.
2. FOR SINGLE ZONE DETECTION, USE TERMINALS 10 AND 13 FOR CLASS B WIRING OR TERMINALS 10 THROUGH 13 FOR CLASS A WIRING. DETECTION ZONE 2 IS ONLY USED FOR CROSS ZONE DETECTION. (CROSS ZONE DETECTION IS NOT PERMITTED IN NEW YORK CITY AND IS NOT FM APPROVED. CONFIRM USE OF CROSS ZONE DETECTION WITH AUTHORITY HAVING JURISDICTION.)
3. TERMINALS 26 THROUGH 31 ARE FOR 24VDC NOTIFICATION DEVICES (NAC).
4. TERMINALS 34 THROUGH 45 ARE DRY CONTACT RELAYS FOR CONNECTION TO MAIN BUILDING FIRE ALARM SYSTEM. ADDRESSABLE MODULES, IF REQUIRED, TO BE PROVIDED BY THE MAIN BUILDING FIRE ALARM SYSTEM SUPPLIER.
5. ALL DETECTION AND NOTIFICATION DEVICES MUST BE COMPATIBLE WITH THE POTTER PFC4410 RELEASING CONTROL PANEL.
6. TERMINALS 46, 47, AND 48 IS THE DRY CONTACT RELAY SET FOR NITROGEN GENERATOR ALARM (WHERE SO EQUIPPED). ADDRESSABLE MODULE, IF REQUIRED, TO BE PROVIDED BY THE MAIN BUILDING FIRE ALARM SYSTEM SUPPLIER.
7. RELOCATE FACTORY INSTALLED END-OF-LINE RESISTORS (EOLR) TO ENDS OF CLASS B DETECTION AND NOTIFICATION CIRCUITS. LEAVE FACTORY INSTALLED EOLR ON ALL UNUSED CIRCUITS.

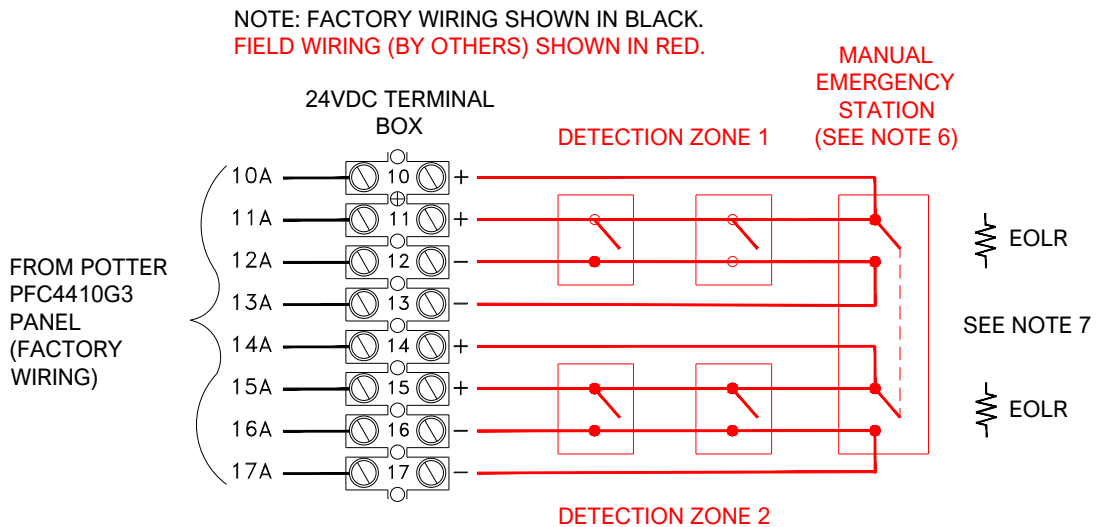

DETECTOR WIRING EXAMPLE (CLASS A)

COMPP_DET_CLA

NOTES:

1. THIS DRAWING IS INTENDED AS A REFERENCE ONLY. DESIGN OF THE DETECTION SYSTEM (BY OTHERS) MUST MEET THE MINIMUM REQUIREMENTS OF NFPA 13, NFPA 72, AND THE AUTHORITY HAVING JURISDICTION.
2. DRAWING INDICATES CROSS ZONE DETECTION. CROSS ZONE DETECTION IS NOT PERMITTED IN NEW YORK CITY AND IS NOT FM APPROVED. CONFIRM USE OF CROSS ZONE DETECTION WITH AUTHORITY HAVING JURISDICTION.
3. FOR SINGLE ZONE DETECTION, USE DETECTION ZONE 1 (TERMINALS 10 THROUGH 13).
4. DETECTION DEVICES, INCLUDING MANUAL EMERGENCY STATIONS, ARE FIELD WIRED BY OTHERS.
5. ALL DEVICES MUST BE COMPATIBLE WITH THE POTTER PFC-4410G3 RELEASING CONTROL PANEL.
6. WHEN USING CROSS ZONE DETECTION, ARRANGE MANUAL PULL STATIONS TO SIMULTANEOUSLY RELEASE DETECTION ZONES 1 AND 2.
7. REMOVE FACTORY INSTALLED END-OF-LINE RESISTORS FROM 24VDC TERMINAL BLOCK AND STORE (EOLR ARE NOT USED ON CLASS A DETECTION CIRCUITS). LEAVE FACTORY INSTALLED EOLR ON ALL UNUSED CIRCUITS.

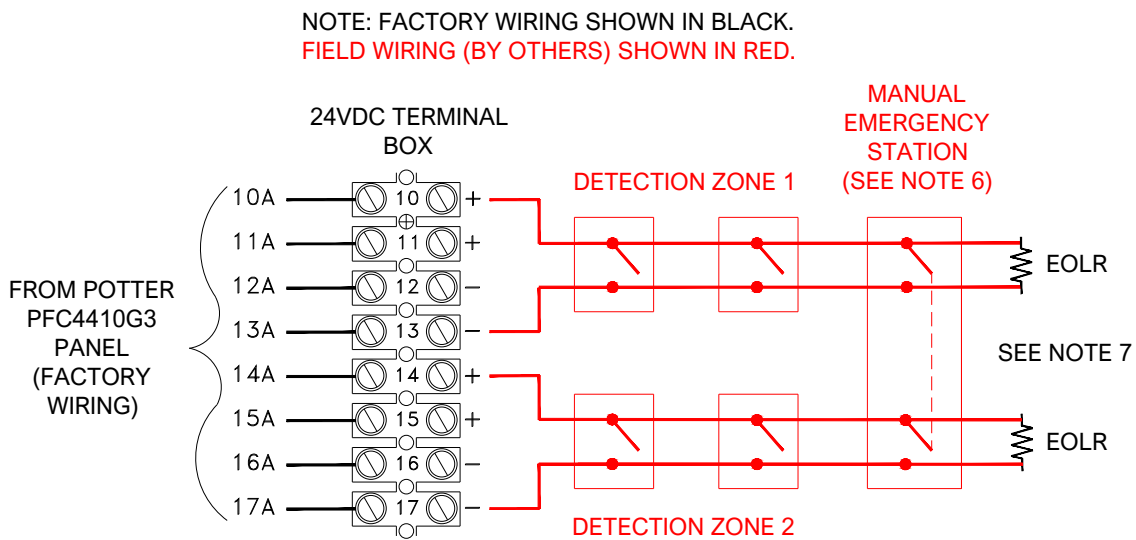

NOTES:

1. THIS DRAWING IS INTENDED AS A REFERENCE ONLY. DESIGN OF THE DETECTION SYSTEM (BY OTHERS) MUST MEET THE MINIMUM REQUIREMENTS OF NFPA 13, NFPA 72, AND THE AUTHORITY HAVING JURISDICTION.
2. DRAWING INDICATES CROSS ZONE DETECTION. CROSS ZONE DETECTION IS NOT PERMITTED IN NEW YORK CITY AND IS NOT FM APPROVED. CONFIRM USE OF CROSS ZONE DETECTION WITH AUTHORITY HAVING JURISDICTION.
3. FOR SINGLE ZONE DETECTION, USE DETECTION ZONE 1 (TERMINALS 10 AND 13).
4. DETECTION DEVICES, INCLUDING MANUAL EMERGENCY STATIONS, ARE FIELD WIRED BY OTHERS.
5. ALL DEVICES MUST BE COMPATIBLE WITH THE POTTER PFC-4410G3 RELEASING CONTROL PANEL.
6. WHEN USING CROSS ZONE DETECTION, ARRANGE MANUAL PULL STATIONS TO SIMULTANEOUSLY RELEASE DETECTION ZONES 1 AND 2.
7. RELOCATE FACTORY INSTALLED END-OF-LINE RESISTORS FROM 24VDC TERMINAL BLOCK TO ENDS OF DETECTION CIRCUITS. LEAVE FACTORY INSTALLED EOLR ON ALL UNUSED CIRCUITS.

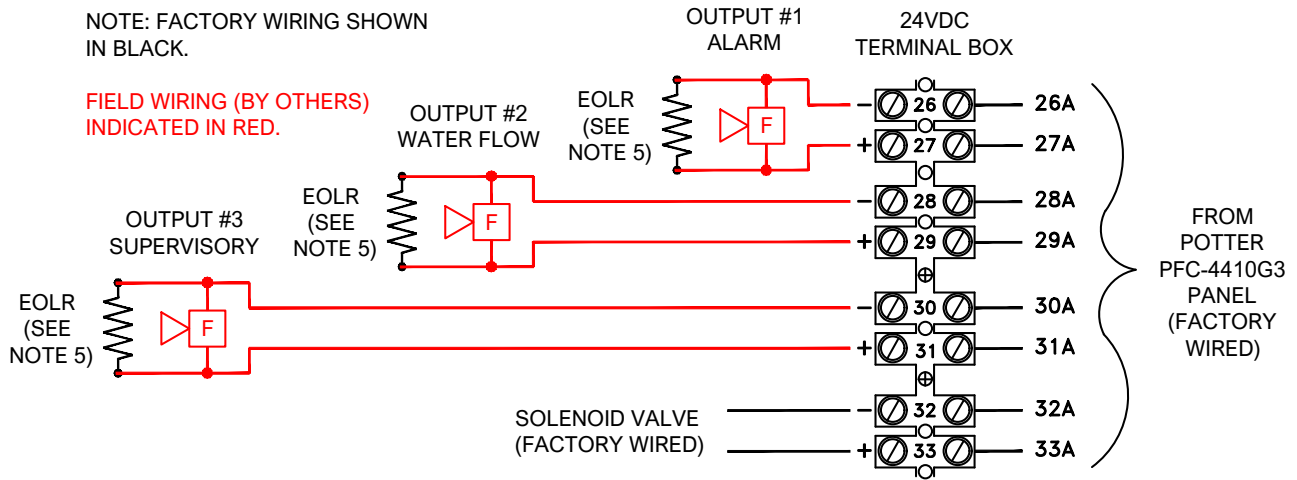

OUTPUT DEVICE WIRING EXAMPLE

COMPP_WIRE_OUTPUT

NOTES:

1. THIS DRAWING IS INTENDED AS A REFERENCE ONLY. DESIGN OF THE NOTIFICATION SYSTEM (BY OTHERS) MUST MEET THE MINIMUM REQUIREMENTS OF NFPA 13, NFPA 72, AND THE AUTHORITY HAVING JURISDICTION.
2. NOTIFICATION DEVICES AND CIRCUITS ARE FIELD WIRED BY OTHERS.
3. ALL DEVICES MUST BE COMPATIBLE WITH THE POTTER PFC-4410G3 RELEASING CONTROL PANEL.
4. OBSERVE POLARITY WHEN CONNECTING DEVICES. POLARITY SHOWN ON OUTPUT CIRCUITS IS IN THE ACTIVATED (OFF-NORMAL) CONDITION.
5. RELOCATED FACTORY INSTALLED END-OF-LINE RESISTORS FROM 24VDC TERMINAL BLOCK TO END OF NOTIFICATION CIRCUITS. LEAVE FACTORY INSTALLED EOLR ON ALL UNUSED CIRCUITS.

9. Releasing Control Panel Programming

The information in the following table applies ONLY to units provided with an integral Potter PFC-4410G3 releasing control panel. Program selection and/or programming of separate, approved releasing control panels should only be done by qualified personnel knowledgeable in the specific operation of each type of system.

System Description	Program	Reference
Type D Single Interlock Preaction, Single Zone Detection	#50	Page 38
Type D Single Interlock Preaction, Cross-Zoned Detection	#51	Page 39
Type D Single Interlock Preaction, New York City	#52	Page 40
Type D Double Interlock Preaction Single Zone Detection	#53	Page 41
Type F Double Interlock Preaction, Single Zone Detection	#50	Page 38
Type F Double Interlock Preaction, Cross-Zoned Detection	#51	Page 39
Deluge Electric Release, Single Zone Detection	#54	Page 42
Deluge Electric Release, Cross-Zoned Detection	#55	Page 43
Non-Interlock Single Zone Detection	#50	Page 38
Non-Interlock Cross-Zoned Detection	#51	Page 39

Single Interlock, Single Zone Detection Potter Program #50 (Also used for Type F Double Interlock Preaction Single Zone Detection)

1. Apply power to panel.
2. Press ENT to enter PROGRAM mode
3. Press 6 or scroll down to #6 and press ENT, (The selection is indicated by a flashing arrow next to the number.
4. Enter the password. (Factory default is 1111)
5. Press 1 or press ENT. (1 should be the highlighted selection)
6. The display shows the current program number. Press 50 to change to program 50. Press ENT.
7. Press 1 to accept the change.
8. Press ENT to accept the change.

OUTPUTS	INPUTS						
	Supervisory (Valves)	Supervisory (Solenoid)	Low Air	High Air	Detection	Detection	Waterflow
	#1	#2	#3	#4	#5	#6	#7
#1 Alarm					X	X (OPT)	
#2 Waterflow							X
#3 Supervisory	X	X	X	X			
#4 Release					X	X (OPT)	

Program 50 Operation

Activation of Supervisory Input #1 or #2 will operate Supervisory Output #3.

Activation of Low Air Input #3 or High Air Input #4 will operate Supervisory Output #3.

Independent activation of EITHER Detection Input #5 or #6 (if used) will operate Alarm Output #1 and Release Output #4.

Activation of Waterflow Input #7 will operate Water Flow Output #2.

Notes:

1. The emergency manual release within the unit is wired into Zone 5 and Zone 6 Detection Inputs, and is provided to release the solenoid for setup and testing purposes.
2. See page 32 for connection of relay contacts to main building fire alarm system.
3. For additional information, please refer to the Installation, Operation, and Instruction Manual for the Releasing Control panel provided with the PrePaK.

Single Interlock, Cross-Zoned Detection Potter Program #51 (Also used for Type F Double Interlock Preaction Cross-Zoned Detection)

1. Apply power to panel.
2. Press ENT to enter PROGRAM mode
3. Press 6 or scroll down to #6 and press ENT, (The selection is indicated by a flashing arrow next to the number.
4. Enter the password. (Factory default is 1111)
5. Press 1 or press ENT. (1 should be the highlighted selection)
6. The display shows the current program number. Press 51 to change to program 51. Press ENT.
7. Press 1 to accept the change.
8. Press ENT to accept the change.

OUTPUTS	INPUTS							Software Zone
	Supervisory (Valves)	Supervisory (Solenoid)	Low Air	High Air	Detection	Detection	Waterflow	Release Zone
	#1	#2	#3	#4	#5	#6	#7	#8
#1 Alarm					X	X		X
#2 Waterflow							X	
#3 Supervisory	X	X	X	X				
#4 Release					XX	XX		XX*

* Release Outputs which are Cross-Zoned need a Software Zone in order to work properly. The Software Zone Number will be displayed upon a release.

XX = Cross-Zoned

Program 51 Operation

Activation of Supervisory Input #1 or #2 will operate Supervisory Output #3.

Activation of the Low Air Input #3 or High Air Input #4 will operate Supervisory Output #3.

Independent activation of EITHER Detection Zone #5 or #6 will operate Alarm Output Zone #1.

Simultaneous activation of BOTH Detection Input #5 AND #6 will operate Release Output #4.

Activation of Waterflow Input #7 will operate Water Flow Output #2

Notes:

1. The emergency manual release within the unit is wired into Zone 5 and Zone 6 Detection Inputs, and is provided to release the solenoid for setup and testing purposes.
2. See page 32 for connection of relay contacts to main building fire alarm system.
3. For additional information, please refer to the Installation, Operation, and Instruction Manual for the Releasing Control panel provided with the PrePaK.

Single Interlock Preaction, New York City Custom Program #52

1. Apply power to panel.
2. Press ENT to enter PROGRAM mode
3. Press 6 or scroll down to #6 and press ENT, (The selection is indicated by a flashing arrow next to the number.
4. Enter the password. (Factory default is 1111)
5. Press 1 or press ENT. (1 should be the highlighted selection)
6. The display shows the current program number. Press 52 to change to program 52. Press ENT.
7. Press 1 to accept the change.
8. Press ENT to accept the change.

OUTPUTS	INPUTS							Software Zone
	Supervisory (Valves)	Supervisory (Solenoid)	Low Air	High Air	Detection	Detection	Waterflow	Trouble Zone
	#1	#2	#3	#4	#5	#6	#7	#8
#1 Alarm						Not Used	X	
#2 Trouble	Panel trouble condition is mapped to Output #2 (Trouble Bell) for NYC							X*
#3 Supervisory	X	X	X	X		Not Used		
#4 Release					X			

*Trouble Output needs a Software Trouble Zone Type in order to work properly. The Software Zone Number will be displayed upon release.

Program 52 Operation

- Activation of Supervisory Input #1 or #2 will operate Supervisory Output #3..
- Activation of Low Air Input #3 or High Air Input #4 will operate Supervisory Output #3.
- Activation of Detection Input #5 will operate Alarm Output #1 and Release Output #4.
- Activation of Waterflow Input #7 will operate Alarm output 1.
- Activation of tany trouble condition with the panel will operate Trouble Output #2

Note:

1. The emergency manual release within the unit is wired into Zone 5 and Zone 6 Detection Inputs, and is provided to release the solenoid for setup and testing purposes.
2. See page 32 for connection of relay contacts to main building fire alarm system.
3. For additional information, please refer to the Installation, Operation, and Instruction Manual for the Releasing Control panel provided with the PrePaK.

Type D Double Interlock Preaction, Single Zone Detection, Program #53

1. Apply power to panel.
2. Press ENT to enter PROGRAM mode
3. Press 6 or scroll down to #6 and press ENT, (The selection is indicated by a flashing arrow next to the number.
4. Enter the password. (Factory default is 1111)
5. Press 1 or press ENT. (1 should be the highlighted selection)
6. The display shows the current program number. Press 53 to change to program 53. Press ENT.
7. Press 1 to accept the change.
8. Press ENT to accept the change

OUTPUTS	INPUTS							Software Zone
	Supervisory (Valves)	Supervisory (Solenoid)	Low Air	High Air	Detection	Detection	Waterflow	Release Zone
	#1	#2	#3	#4	#5	#6	#7	#8
#1 Alarm					X	Not Used		X
#2 Waterflow							X	
#3 Supervisory	X	X	X	X				
#4 Release			XX		XX			XX*

* Release Outputs which are Cross-Zoned need a Software Zone in order to work properly. The Software Zone Number will be displayed upon a release.

XX = Cross-Zoned

Program 53 Operation

Activation of Supervisory Input #1 or #2 will operate Supervisory Output #3.

Independent activation of Low Air Input #3 or activation of High Air Input #4 will operate Supervisory Output #3.

Activation of Detetion Input #5 will operate Alarm Output #1.

Simultaneous activation of BOTH Detection Input #5 AND Low Air Input #3 will operate Release Output #4.

Activation of Waterflow Input #7 will operate Water Flow Output #2..

Notes:

1. The emergency manual release within the unit is wired into Zone 5 and Zone 6 Detection Inputs, and is provided to release the solenoid for setup and testing purposes.
2. See page 32 for connection of relay contacts to main building fire alarm system.
3. For additional information, please refer to the Installation, Operation, and Instruction Manual for the Releasing Control panel provided with the PrePaK.

Electric Release Deluge, Single Zone Detection, Program #54

1. Apply power to panel.
2. Press ENT to enter PROGRAM mode
3. Press 6 or scroll down to #6 and press ENT, (The selection is indicated by a flashing arrow next to the number.
4. Enter the password. (Factory default is 1111)
5. Press 1 or press ENT. (1 should be the highlighted selection)
6. The display shows the current program number. Press 54 to change to program 54. Press ENT.
7. Press 1 to accept the change.
8. Press ENT to accept the change.

OUTPUTS	INPUTS							
	Supervisory (Valves)	Supervisory (Solenoid)	Low Air	High Air	Detection	Detection	Waterflow	
	#1	#2	#3	#4	#5	#6	#7	
#1 Alarm Indicating			Not Used	Not Used	X	X (OPT)		
#2 Trouble								X
#3 Supervisory	X	X						
#4 Release							X	X (OPT)

Program 54 Operation

Activation of Supervisory Input #1 or #2 will operate Supervisory Output #3.

Independent activation of EITHER Detection Input #5 or #6 (if used) will operate Alarm Output

When either zone 3 or 4 is in alarm, outputs 1 & 3 will operate #1 and Release Output #4.

Activation of Waterflow Input #7 will operate Water Flow Output #2.

Notes:

1. The emergency manual release within the unit is wired into Zone 5 and Zone 6 Detection Inputs, and is provided to release the solenoid for setup and testing purposes.
2. See page 32 for connection of relay contacts to main building fire alarm system.
3. For additional information, please refer to the Installation, Operation, and Instruction Manual for the Releasing Control panel provided with the PrePaK.

Electric Release Deluge, Cross-Zoned Detection, Program #55

1. Apply power to panel.
2. Press ENT to enter PROGRAM mode
3. Press 6 or scroll down to #6 and press ENT, (The selection is indicated by a flashing arrow next to the number.
4. Enter the password. (Factory default is 1111)
5. Press 1 or press ENT. (1 should be the highlighted selection)
6. The display shows the current program number. Press 55 to change to program 55. Press ENT.
7. Press 1 to accept the change.
8. Press ENT to accept the change

OUTPUTS	INPUTS							Software Zone	
	Supervisory (Valves)	Supervisory (Solenoid)	Low Air	High Air	Detection	Detection	Waterflow	Release Zone	
	#1	#2	#3	#4	#5	#6	#7	#8	
#1 Alarm Indicating			Not Used	Not Used	X	X		X	
#2 Waterflow								X	
#3 Supervisory	X	X							
#4 Release						XX	XX		XX*

* Release Outputs which are Cross-Zoned need a Software Zone in order to work properly. The Software Zone Number will be displayed upon a release

XX = Cross-Zoned

Program 55 Operation

Activation of Supervisory Input #1 or #2 will operate Supervisory Output #3.

Independent activation of EITHER Detection Input #5 or #6 will operate Alarm Output #1

Simultaneous activation of BOTH Detection Input #5 AND #6 will operate and Release Output #4.

Activation of Waterflow Input #7 will operate Water Flow Output #2.

Notes:

1. The emergency manual release within the unit is wired into Zone 5 and Zone 6 Detection Inputs, and is provided to release the solenoid for setup and testing purposes.
2. See page 32 for connection of relay contacts to main building fire alarm system.
3. For additional information, please refer to the Installation, Operation, and Instruction Manual for the Releasing Control panel provided with the PrePaK.

10. Field Wiring: Units Without Releasing Control Panel

For PrePaK™ units provided without an integral release panel, a separate listed and approved releasing control panel must be provided by others to perform detection, release, local notification, and monitoring functions. All factory installed electrical devices in the PrePaK™ are factory wired (mapped) to a watertight junction box located in the interior upper left corner of the unit. All field wiring occurs within the watertight junction box. Field wiring requirements will differ depending on the type of system and whether Class B (two-wire) or Class A (four-wire) circuitry is used.

Note: The release control panel selected for use must be compatible with the Parker Hannifin 73218BN4UNLVNOC111C2 or 73212BN4TNLVNOC322C2 solenoid provided as part of the listed and approved valve trim.

Please refer to Figure 24 on the following page.

A. Electric Release Systems

For electric release units (Type D, Type F, electric release deluge, and non-interlock), a 24VDC input from the separate releasing control panel must be connected to solenoid valve terminals 32 and 33 in the watertight junction box. Observe polarity when connecting the to the terminal block. The end-of-line resistor/diode assembly required for the solenoid valve has been factory wired.

In addition to the solenoid power connection above, the customer must provide 24VDC auxiliary power to terminals 2 and 3 of the terminal block to power the Releasing Circuit Disable Switch (RCDS) and connect terminals 44 and 45 to a supervisory circuit in a separate, approved releasing control panel.

B. Monitoring

System monitoring devices must be connected to the releasing control panel in the field using the following terminals in the watertight junction box.

1. Valve supervisory (tamper) switch(es): Terminals 6 and 7 for Class B wiring, or terminals 6, 7, 8, and 9 for Class A wiring.
2. Low air/nitrogen pressure switch: Terminals 22 and 35 for Class B wiring, or terminals 22, 23, 24, and 25 for Class A wiring. (Note: Low air/nitrogen pressure switch is not used on deluge systems.)
3. Water flow alarm switch: Terminals 18 and 21 for Class B wiring, or terminals 18, 19, 20, and 21 for Class A wiring.
4. Nitrogen Generator alarm: Terminals 48, 49, and 50 (depending on normally open or closed circuit)

C. End-of-Line (EOL) Resistors

The following terminals will need connected across an EOL having impedance that is compatible with the releasing control panel:

1. Valve Supervisory Loop: Terminals 8 and 9
2. RCDS Loop: Terminals 46 and 47

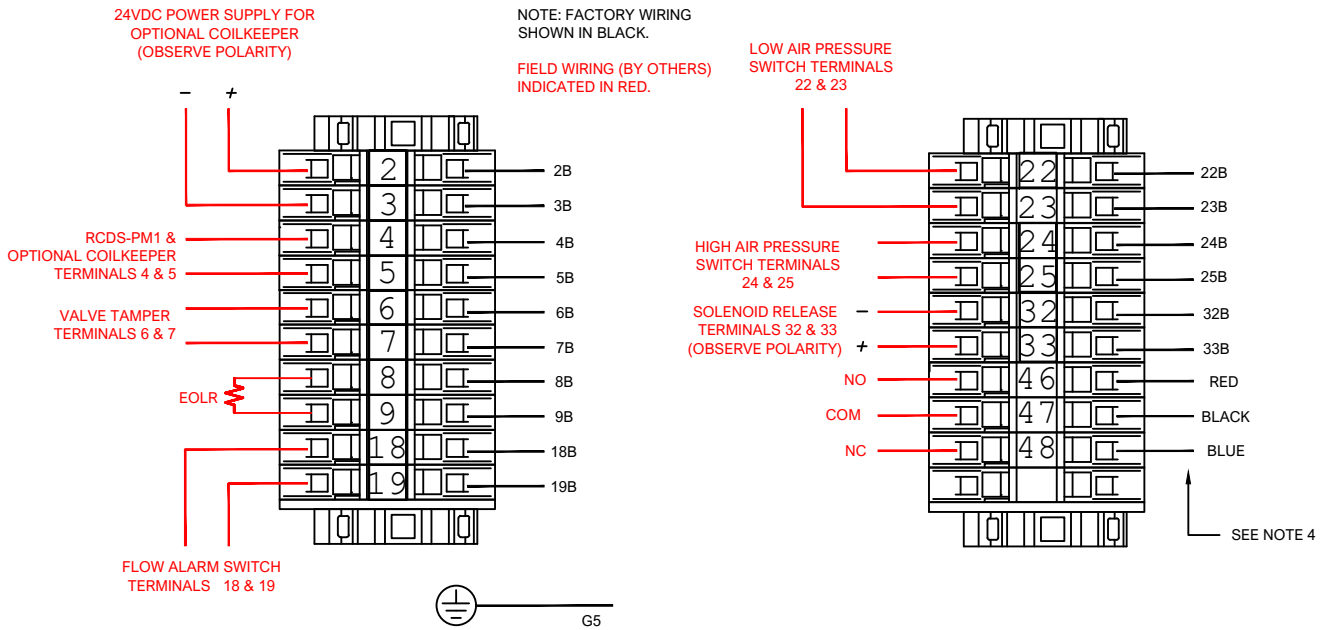

WIRING FOR UNITS WITHOUT INTEGRAL RELEASING PANEL

COMPP_WIRE_NOPANEL_A

NOTES:

1. THIS DRAWING IS INTENDED AS A REFERENCE ONLY. DESIGN OF THE DETECTION, RELEASE, AND NOTIFICATION SYSTEM (BY OTHERS) MUST MEET THE MINIMUM REQUIREMENTS OF NFPA 13, NFPA 72, AND THE AUTHORITY HAVING JURISDICTION.
2. RELEASING CONTROL PANEL MUST BE COMPATIBLE WITH THE SOLENOID VALVE PROVIDED WITH THE SYSTEM.
3. END-OF-LINE RESISTORS (EOLR) PROVIDED BY RELEASE CONTROL PANEL SUPPLIER.
4. TERMINALS 46, 47, AND 48 ARE FOR NITROGEN GENERATOR ALARM (WHERE SO EQUIPPED).

11. Addressable Fire Alarm Systems

Reliable PrePaK™ units are easily adaptable for use with addressable fire alarm systems by utilizing the following modules compatible with the specific brand of addressable system:

A. For units with an integral Potter PFC-4410G3 Releasing Control Panel, provide a single-input module (SIM) to address each of the following Class C contact signals reporting out of the system:

1. Supervisory: terminals 40 and 41
2. Trouble: terminals 34, 35, and 36; depending on normally open or closed circuit
3. Alarm (terminals 37, 38, and 39; depending on normally open or closed circuit)
4. Water flow: terminals 42 and 43
5. Nitrogen generator alarm, where so equipped: terminals 48, 49, and 50 depending on normally open or closed circuit

B. For units without the integral Potter PFC-4410G3 Releasing Control Panel, provide a single-input module (SIM) to address each of the following Class C contact signals reporting out of the system:

1. Valve supervisory switch: terminals 6 and 7
2. High/low system pressure switch: terminals 22 and 25 (Class B wiring), or terminals 22, 23, 24, and 25 (Class A wiring)
3. Releasing Circuit Disable Switch (RCDS): terminals 44 and 45
4. Water flow alarm pressure switch: terminals 18 and 21 (Class B wiring), or terminals 18, 19, 20, and 21 (Class A wiring)
5. Nitrogen generator alarm, where so equipped: terminals 48, 49, and 50 depending on normally open or closed circuit

Also, for units without the integral Potter PFC-4410G3 Releasing Control Panel, provide:

1. A notification application circuit (NAC) module that is listed to perform release function to operate the normally closed solenoid valve. Connect the NAC module to terminals 32 and 33, observing polarity. The end-of-line resistor/diode assembly required for the solenoid valve has been factory wired.
2. A constant 24 VDC power supply to terminals 2 and 3 for the Releasing Circuit Disable switch. Observe polarity when connecting power supply.

12. Supervisory Air/Nitrogen Pressure Requirements

Except for electric release deluge and wet pilot line deluge systems, all Reliable PrePaK™ cabinet mounted systems require air or nitrogen pressure for operation and/or supervision. In most cases, a tank-mounted air compressor within the unit serves this purpose. When ordered without an air compressor, a dependable, clean, and continuous source of compressed air or nitrogen must be provided for connection to the pressure maintenance device in the unit.

Please note that tank-less compressors and nitrogen generators that do not incorporate a tank are NOT compatible with PrePaK™ systems.

Type D single/double interlock preaction systems and single interlock preaction systems with wet pilot line detection do not utilize a pneumatic actuator or other diaphragm operated device as part of the trim. A pressure of 10 psi (0.7 bar) is maintained by the Reliable Model A pressure maintenance device provided with the unit. A model PS10-2 pressure switch serves to notify the fire alarm system of low-pressure condition in the system. On Type D electric/electric double interlock preaction systems the low-pressure switch also serves as the second electric release mechanism for the system.

All other systems incorporate a diaphragm-operated pneumatic actuator as part of the trim. Appropriate air or nitrogen pressure for these systems is required to offset the water pressure operating on the opposite side of the actuator diaphragm, consequently, it may be necessary to adjust the air or nitrogen pressure in the system using the Model A Pressure Maintenance Device. After loosening the regulator lock nut, turn the adjustment screw clockwise to increase system pressure or counterclockwise to reduce system pressure. Tighten the locknut on the regulator following adjustment to prevent accidental changes in the pressure setting. See Figure 25 for the recommended air or nitrogen pressure required. Fastest valve operation is achieved with the pressure shown, however, the pressure must never be less than indicated, and in no case should the air or nitrogen pressure exceed 30 psi.

Note: For systems incorporating a Reliable Model B-1 accelerator, the minimum air or nitrogen pressure required for proper operation is 15 psi (1.0 bar). Failure to provide the minimum pressure will result in unintended operation or non-operation of the accelerator. Additional detailed information on the Model B-1 accelerator can be found on Reliable technical bulletin #323.

Air Compressor Options

For PrePaK™ units that do not incorporate an integral nitrogen generator, nine air compressor options are available. Customer is responsible for specifying the air compressor based upon system capacity, maximum fill time, and electrical characteristics. Available air compressors:

1. 1/2 HP, 110 VAC, 60 Hz; Reliable QRM2-50115T
2. 1 HP, 110 VAC, 60 Hz; Reliable QRM2-100115T
3. 1-1/2 HP, 110 VAC, 60 Hz; General Air Products OL915150AC
4. 1/2 HP, 220 VAC, 60 Hz; Reliable QRM2-50220T
5. 1 HP, 220 VAC, 60Hz; Reliable QRM2-100220T
6. 1-1/2 HP, 220 VAC, 60Hz; General Air Products OL915150AC
7. 1/2 HP, 220 VAC, 50Hz; Reliable QRM2-50220T-50HZ
8. 1 HP, 220 VAC, 50 Hz; Reliable QRM100220T-50HZ
9. 1-1/2 HP, 220 VAC, 50 Hz; General Air Products OL2870150AC-50

For information regarding Reliable QRM2 air compressors, please refer to:

<https://www.reliablesprinkler.com/product/model-qrm-riser-mount-air-compressors/>

For information regarding General Air Products air compressor, please refer to:

<https://www.generalairproducts.com/fire-protection-products/fire-protection-air-compressors/>

Supervisory Air/Nitrogen Pressure Requirements**Figure 25**

Water Pressure psi (bar)	System Air or Nitrogen Pressure psi (bar)
Maximum	Not Less Than
20 (1.4)	8 (0.6)
30 (2.1)	10 (0.7)
50 (3.4)	12 (0.8)
75 (5.2)	13 (0.9)
100 (6.9)	15 (1.0)
125 (8.6)	16 (1.1)
150 (10.3)	17 (1.2)
175 (12.1)	18 (1.2)
200 (13.8)	19 (1.3)
225 (15.5)	21 (1.4)
250 (17.2)	22 (1.5)
275 (19.0)	23 (1.6)
300 (20.7)	24 (1.7)

Special Note for Non-Interlock Systems: Do NOT exceed the “Not Less Than” air or nitrogen pressure in the table above by more than 2 psi (.14 bar). Exceeding this pressure may result in the failure of the non-interlock system to operate in single-interlock mode. Do not use non-interlock systems where water supply is less than 50 psi (3.4 bar).

Nitrogen Generator Option

Reliable Type D, Type F, and DDX-LP PrePaK™ up to 6” (150mm) size are available with an optional, fully integrated South-Tek Systems FPS-900 N2Blast® nitrogen generator. For operation and maintenance of the nitrogen generator, please refer to:

[SouthTek_OM_FPS_N2Blast_900_RS_Operating_Manual_Rev4.pdf \(southteksystems.com\)](#).

A copy of the manual is included with each PrePaK™ equipped with an integral nitrogen generator.

When provided with an integral nitrogen generator, a supplemental air compressor is required in order to meet the fill times required by NFPA 13. Customer is responsible for specifying the air compressor based upon system capacity, maximum fill time, and electrical characteristics. Available air compressors:

1. 1/2 HP, 110 VAC, 60 Hz; Reliable QRM2-50115T
2. 1 HP, 110 VAC, 60 Hz; Reliable QRM2-100115T
3. 1/2 HP, 220 VAC, 60 Hz; Reliable QRM2-50220T
4. 1 HP, 220 VAC, 60Hz; Reliable QRM2-100220T

For information regarding Reliable QRM2 air compressors, please refer to:

<https://www.reliablesprinkler.com/product/model-qrm-riser-mount-air-compressors/>

13. Setting & Resetting System

Set up or reset the system following these steps (note that some steps may not be necessary if previously done):

1. Close the main valve controlling water supply to the deluge valve
 2. Close the valve(s) supplying air or nitrogen to the system
 3. Close the pushrod chamber supply valve.
 4. Open the main drain valve and drain the system.
 5. Open all drain valves at low points throughout the system, closing them when flow of water has stopped.
 6. Open the Manual Emergency Release Valve. Note: This step relieves any remaining hydraulic pressure in the pushrod chamber of the deluge valve.
 7. Push in the plunger of the velocity check (ball drip) valve to force the ball from its seat and drain any water in the alarm line.
 8. With the Model B Manual Emergency Station open, push in and rotate the deluge valve external reset knob counterclockwise (when facing valve) until you hear a distinct clicking noise, indicating that the clapper has closed. Note that the reset knob can be rotated only after pressure in the pushrod chamber is relieved (see step 6).
 9. If resetting the valve following a fire, inspect and replace any portion of the sprinkler system subjected to fire conditions.
 10. Verify that the following valves are in their respective positions:
 - a. Manual Emergency Release – open
 - b. Main Drain Valve – open
 - c. Velocity Check Isolation Valve - closed
 - d. Alarm Test Valve – closed
 - e. Condensate Drain valve – closed
 - f. Air or nitrogen supply Valves – closed
 - g. Solenoid valve (if so equipped) – open
 - h. Wet pilot line (if so equipped) – open
 11. Open the pushrod chamber supply the valve and allow water to flow through the Manual Emergency Release valve.
 12. Close the Manual Emergency Release valve, diverting water to automatic release devices (i.e., solenoid valve, dry pilot actuator, wet pilot line) until a solid stream of water is obtained, and all air is removed from the release line.
 13. While water is flowing through the release line, close the release devices:
 - a. For systems using wet pilot line detection: close the valve allowing water to discharge from the wet pilot line.
 - b. For systems using a dry pilot (pneumatic) actuator: Rapidly apply air or nitrogen pressure to the system and/or dry pilot line forcing the actuator to close. Allow pneumatic pressure to stabilize, and place air or nitrogen supply into automatic operation.
 - c. For systems using a solenoid valve: De-energize (close) the solenoid by resetting the releasing control panel.
- Note: On Type F double interlock preaction systems, it is important that the LP dry pilot actuator be closed before the solenoid valve. This will ensure there is no air or nitrogen in the space between the solenoid and the actuator.**
14. Verify that full hydraulic pressure builds in the pushrod chamber.
 15. Slightly open the main valve controlling water supply to the Model DDX Deluge Valve.
 16. Slowly close the main drain valve.
 17. Verify that full hydraulic pressure builds below the Model DDX deluge valve clapper.
 18. Open the velocity check (ball drip) isolation valve and observe if water leaks through the velocity check valve into the drain manifold. If no leak occurs, the deluge valve clapper is sealed.
 19. Fully open the valve controlling water supply and verify the valve is properly monitored.
 20. Verify that the pushrod chamber supply valve is fully open, and if desired, secure the valve in the open position. It is imperative that constant hydraulic pressure be provided to the pushrod chamber to offset any small leaks in the release trim.
 21. Secure the handle of the Model B Manual Emergency Station in the OFF position with a breakable nylon tie.
 22. Notify all concerned parties that the fire system has been placed into an operational condition.

14. Inspection

Note: Information in this section is provided for reference and is not intended as a substitute for the requirements of NFPA 25 and/or the authority having jurisdiction.

The Reliable PrePaK™ and associated equipment shall periodically be given a thorough inspection. NFPA 25 "Inspection, Testing and Maintenance of Water Based Fire Protection Systems" provides minimum inspection requirements. System components shall be inspected in accordance with the latest requirements of NFPA 25 and any deficiencies shall be corrected.

Any inspection that involves placing a control valve or detection/control system out of service may eliminate the fire protection that is provided by the fire protection system. Notify all concerned parties when inspection activities are being performed.

1. Verify the valve controlling water supply to the deluge valve is fully opened and properly monitored.
2. Verify the alarm test valve is fully closed.
3. Verify the velocity check isolation valve is open.
4. Verify the pushrod chamber supply valve is fully opened.
5. Verify all pressure gauge valves are open and normal pressures are present.
6. Push in on the plunger to be sure the ball check is off its seat. If no water appears, the deluge valve water seat is tight.
7. Inspect the bleed hole on the underside of the pushrod chamber for leakage.
8. Verify that proper system air or nitrogen pressure is maintained on the system and/or dry pilot line.
9. Check the outlet of the releasing devices (solenoid valve, Model B Manual Emergency Station, pneumatic actuator, and/or pilot lines) for leakage.
10. Verify that tubing drain lines from releasing devices are not pinched or crushed which could prevent proper releasing of the deluge valve.
11. Verify the Manual Emergency Station valve is secured in the closed position with a breakaway cable tie.

15. Testing

Note: Information in this section is provided for reference and is not intended as a substitute for the requirements of NFPA 25 and/or the authority having jurisdiction.

The Reliable PrePaK™ and associated equipment shall periodically be given a thorough test. NFPA 25 “Inspection, Testing and Maintenance of Water Based Fire Protection Systems” provides minimum testing requirements. System components shall be tested in accordance with the latest requirements of NFPA 25 and any deficiencies shall be corrected.

Any system testing that involves placing a control valve or detection/control system out of service may eliminate the fire protection that is provided by the fire protection system. Notify all concerned parties when testing activities are being performed.

Water flow and low/high pressure switch testing

1. Water flow alarm — Open the alarm test valve permitting water to flow to and activate the alarm pressure switch and/or mechanical sprinkler alarm. After testing, close this valve completely. Push in on the plunger of ball drip until all water has drained from the alarm line.
2. Low air or nitrogen pressure alarm (may not be present on all systems) — Close the valve controlling air or nitrogen supply to the system or dry pilot line. Slowly open the condensate drain valve on the deluge valve or test valve on the dry pilot line. Verify that a low-pressure signal is received. (Important! Rapid release of pressure on a DDX-LP dry system or systems using dry pilot line detection may result in full operation of the system. Exercise caution during this test to ensure a low-pressure signal is initiated prior to operation of these systems.) Close the test valve, reopen the air or nitrogen supply valve, and allow system to return to normal operating pressure.
3. High air or nitrogen pressure alarm (may not be present on all systems) — Slowly open the quick-fill bypass valve on the Model A pressure maintenance device allowing tank pressure into the system or dry pilot line. Verify that a high-pressure signal is received. (Note: This test may also result in operation of the system air or nitrogen pressure relief valve.) Close the quick-fill bypass valve, slowly open a valve on the system or dry pilot line and allow the system to return to normal operating pressure before closing the valve.

Operational Testing Without Causing Water Flow

1. Close the main valve controlling water supply to the deluge valve.
2. Open the main drain valve.
3. Verify that the pushrod chamber supply valve is open, and the push-rod chamber is hydraulically pressurized.
4. For Model DDX-LP low-pressure dry system: Open the condensate drain valve on the deluge valve and allow air to evacuate from the system. The loss of air pressure in the system should result in a sudden drop of water pressure in the pushrod chamber indicating operation of the dry pilot actuator.
5. For single interlock preaction systems and deluge systems: Operate the detection system. This should result in a sudden drop of water pressure in the pushrod chamber indicating operation of the release device.
6. For double interlock preaction systems: Close the valve controlling air or nitrogen supply to the system. Operate the detection system. Open the condensate drain valve on the deluge valve and allow air to evacuate from the system. The loss of air pressure in the system combined with an active detection event should result in a sudden drop of pressure in the pushrod chamber indicating operation of the release devices.
7. Restore detection system (where applicable) and air or nitrogen pressure (where applicable) and ensure pushrod chamber is hydraulically pressurized before opening the main control valve on the system.

Full operational testing, which will result in water flow into the system, is accomplished by starting on step 3 above (i.e., leaving full system pressure on the system). The sudden drop of pressure in the pushrod chamber referenced in items 4, 5, and 6 should be accompanied by release of the deluge valve.

16. Maintenance

Note: Information in this section is provided for reference and is not intended as a substitute for the requirements of NFPA 25 and/or the authority having jurisdiction.

The Reliable PrePaK™ and associated equipment shall regularly maintained. NFPA 25 “Inspection, Testing and Maintenance of Water Based Fire Protection Systems” provides minimum maintenance requirements. System components shall be maintained in accordance with the latest requirements of NFPA 25.

Any system maintenance that involves placing a control valve or detection/control system out of service may eliminate the fire protection that is provided by the fire protection system. Notify all concerned parties when maintenance activities are being performed.

System condensation—Periodically remove accumulation of water in the deluge valve due to condensation following these steps:

1. Close the main valve controlling water supply to the deluge valve.
2. Close the pushrod chamber supply valve.
3. Open the main drain valve.
4. Slightly open the condensate drain valve until all water drains completely.
5. Close the condensate drain. (Note: Leaving the condensate drain valve open for an extended period may allow excess air to bleed off resulting in an undesirable low pressure supervisory signal.)
6. Close the main drain valve.
7. Allow the system air pressure to return to its previous level.
8. Open the pushrod chamber supply valve and verify the pushrod chamber is hydraulically pressurized.
9. Open the main valve controlling the water supply to the deluge valve.

Air compressor tank condensation — Periodically remove accumulation of water in the air compressor tank due to condensation following these steps:

1. Slowly open the condensate drain valve on bottom of the tank, allowing air pressure to force any accumulated water from the tank.
2. Close the condensate drain valve when water is drained. (Note: Leaving the condensate drain valve open for an extended period may allow excess air to bleed off and signal the air compressor to start.)

Desiccant dryer (where so equipped)—When silica gel desiccant color or moisture indicator has changed from Blue (meaning dry) to Pink (meaning wet), replace the desiccant following these steps:

1. Turn off and depressurize the line containing the dryer unit.
2. Loosen the clamp ring and remove the bowl from the top housing.
3. Pour out used desiccant.
4. Open new container and refill bowl.
5. Shake or tap bowl to settle desiccant.
6. Add or remove sufficient quantity to fill bowl to 1/8” below inner step
7. Replace bowl and bowl guard, or metal bowl, and clamp ring onto the unit. Be sure clamp ring is securely locked in place before repressurizing the unit.

For replacement desiccant, contact the Wilkerson Corporation, Richland MI.

