



## Model D Dry Pipe Valve

# Instructions for Installation, Operation, Care and Maintenance

### 4" (100 mm) – 6" (150 mm) Valve With Model D Trimmings

Listed by Underwriters Laboratories, Inc. Approved by 'FM Approvals' and other fire insurance and governmental agencies in the United States and foreign countries.

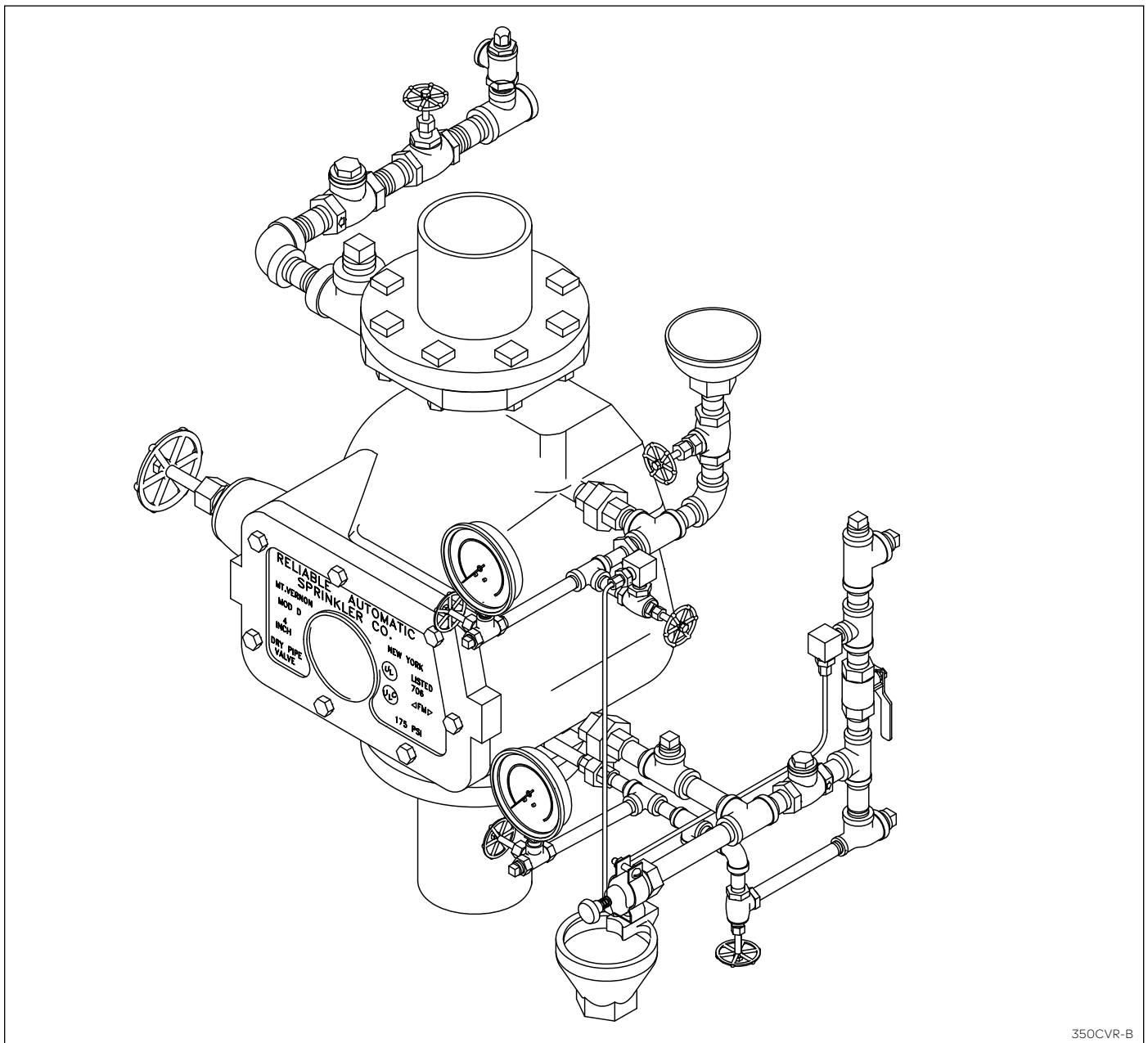

350CVR-B

## General

Reliable Model D Dry Pipe Valves are installed in the vertical position in the main supply to the dry pipe system. The basic trim set, priming chamber attachment and fill line attachment are described below and are separately ordered and supplied. Additional items such as air maintenance devices, air compressors, alarm switches, etc. are described and installed in accordance with their respective product bulletins.

## Valve Description

1. Rated working pressure - 175 psi (12.1 bar).
2. Factory hydrostatic test pressure - 350 psi (24.2 bar).
3. End and trim connections - Three valve connection styles are available:
  - a. US Standard Flanged Inlet and Outlet:

U.S. Flange Dimensions in inches					
Valve Size	Bolt Circle Dia.	Bolt Hole Dia.	Flange Outside Dia.	Flange Thickness	No. Bolts
4" (100 mm)	7 1/2	3/4	9	15/16	8
6" (150 mm)	9 1/2	7/8	11	1	8

- Threaded openings per ANSI B 1.20.1.
  - Reliable's standard trim sets are compatible with Flanged Valves.
  - Color - Black.
- b. US Standard Flanged Inlet and Grooved Outlet (Fig. A):
    - Inlet flange mates with ANSI B 16.1 (125 lb) Flange.
    - Outlet groove dimensions per ANSI/AWWA C606.

U.S. Groove Dimensions in inches				
Valve Size	Outlet Dia.	Groove Dia.	Groove Width	Outlet Face to Groove
4" (100 mm)	4.500	4.334	3/8	5/8
6" (150 mm)	6.625	6.455	3/8	5/8

- Threaded openings per ANSI B 1.20.1.
- Reliable's standard trim sets are compatible with US Flanged and Grooved Valves.
- Color - Black.

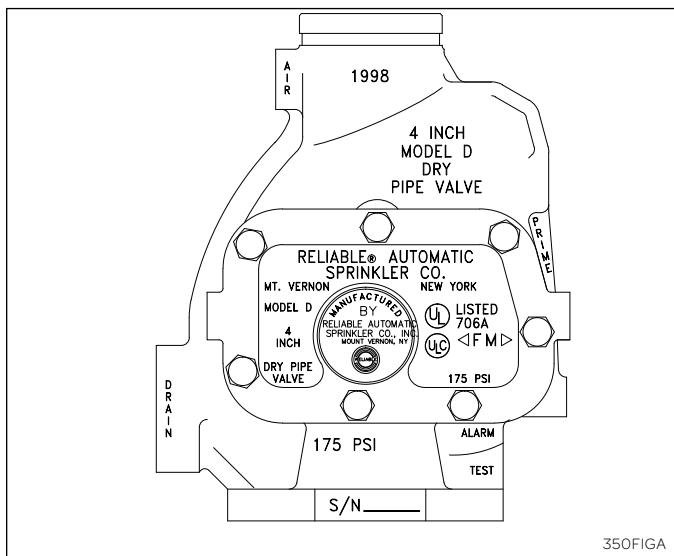

Figure A

- c. Metric Flanged Inlet and Outlet:
  - Flanges mate with EN1092-2 8.66, NF-E-29-282 and BS 4504 PN 16 Flanges.

Metric Flange Dimensions in Millimeters					
Valve Size	Bolt Circle Dia.	Bolt Hole Dia.	Flange Outside	Flange Thickness	No. Bolts
100 mm	180	18.3	229	23.8	8
150 mm	241	22.2	279	25.4	8

- Threaded openings per ISO 7/1-R.
  - Reliable's standard trim sets may be used with metric valves providing trim is assembled carefully and extra thread sealant is applied to connections between valves and trim.
  - Color - Red.
4. Face to Face Dimension:
    - The 4" (100 mm) valve - 16" (406 mm).
    - The 6" (150 mm) valve - 19" (482 mm).
  5. Friction Loss - Expressed in Equivalent Length of Pipe, Based on Hazen-Williams formula with C=120:
 

	<u>Equiv. Length</u>
• The 4" (100 mm)	28' (8.51 m)
• The 6" (150 mm)	47' (14.29 m)
  6. Installation Position: Vertical.

## Valve Installation

When the dry pipe valve is to be placed on top of an OS&Y gate valve, the use of 4 stud bolts and 4 nuts is needed to connect the bottom flange of the Dry Pipe Valve to the top flange of the OS&Y gate valve.

Dry Pipe Valve Size	Stud Bolt	
	Dia.	Length
4" (100 mm)	5/8"	6"
6" (150 mm)	3/4"	3 1/2"

Insert the 4 stud bolts in the top flange holes of the OS&Y gate valve. Push stud bolts up through flange holes of dry pipe valve and attach nuts. Complete bolting with uniform tightening.

## Assembly of Model D Trim

All valves are Listed by Underwriters Laboratories, Inc. and Approved by 'FM Approvals' only when used with the valve manufacturer's trim sets.

## Basic Trim

The assembled basic trim set is shown in Figures B and C.

1. Install 1/4" Nipple (42) in tapped opening marked TEST and attach half of 1/4" Union (26).
2. Install 1/2" Nipple (47) in tapped opening marked ALARM and connect parts in proper order through Check Valve (12) to 1/4" Union (26).

**Note:** Check Valve (12) must allow flow from the dry pipe valve to the alarm line.

3. Connect balance of trimming parts in any desired order.
4. A Model B Strainer must be installed as shown, when ever a Model C Mechanical Water Motor Alarm is used. The strainer must be in a horizontal line to protect the nozzle in the water motor and it must be accessible for cleaning.
5. Drain pipe from Drip Cup (2) should be run as directly as possible to an open drain. If it is absolutely necessary to connect it to the 2" main drain line, install a check valve in the drip cup drain line at least 4 feet below the drip cup so as to give proper head for discharge of water into the main drain line. See NFPA 13 for additional requirements.

### Priming Chamber and Fill Line Attachments

The assembled priming chamber and fill line attachments are shown in Figure D.

### Hydrostatic Testing of Dry Pipe System

When conducting hydrostatic test of system piping at pressures in excess of 50 psi (3.44 bar), be sure the dry pipe valve clapper is either latched in wide open position or removed from valve. Otherwise, injury to the valve may occur.

### Operation

The normal position of the dry pipe valve parts is shown in Figure E.

When air pressure in the system drops due to the opening of one or more sprinklers, the Clapper Assembly (5), through the greater force exerted on its underside by the water supply pressure, moves upward rotating to its open position and is held in this position by the Latch. Water from the supply instantly flows through the dry pipe valve into the sprinkler system piping. Water also flows through the alarm outlet to the electric alarm switch and water motor causing alarms to be sounded.

### Installation Dimensions For 4" (100 mm) Valve and 6" (150 mm) Valve

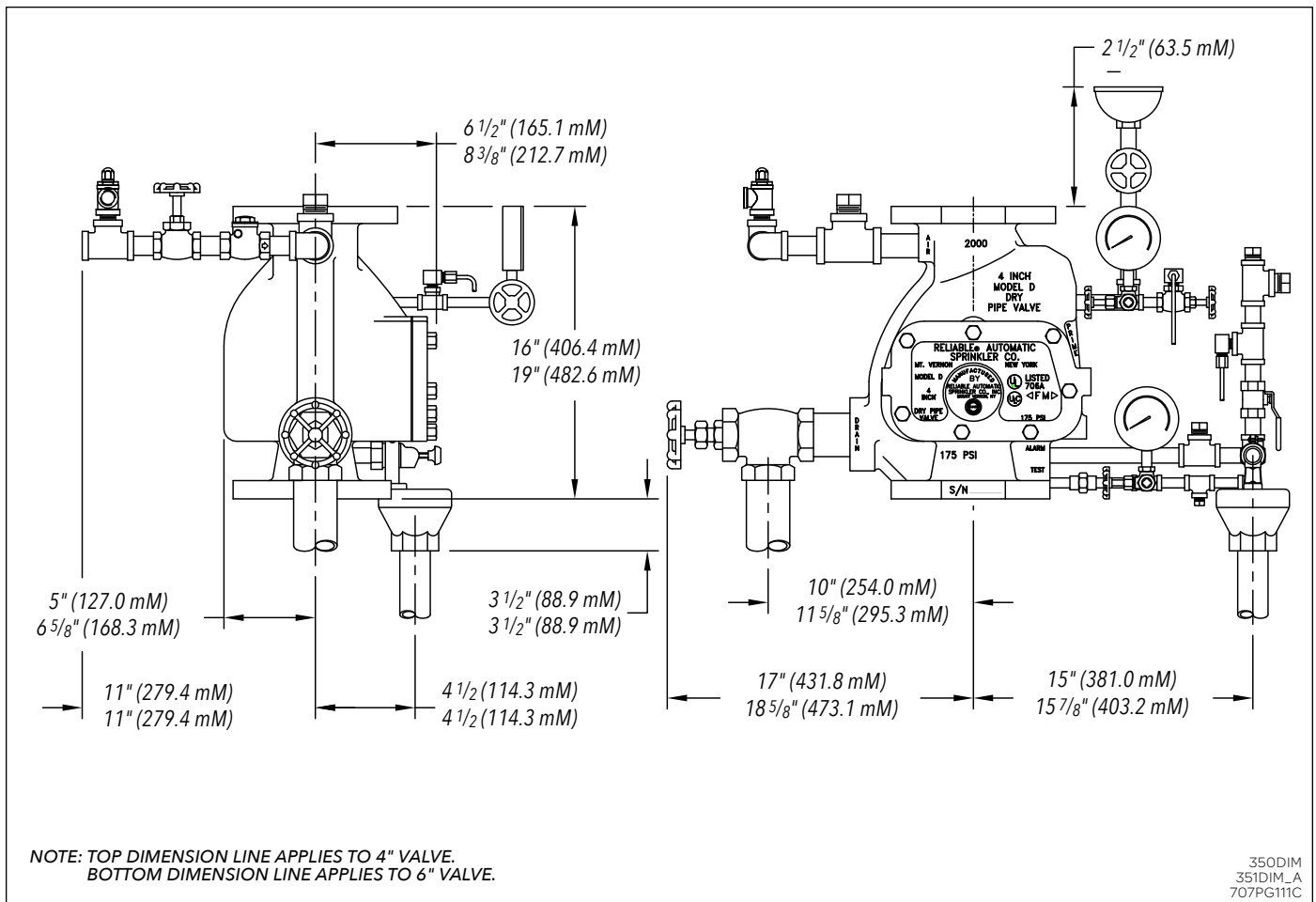

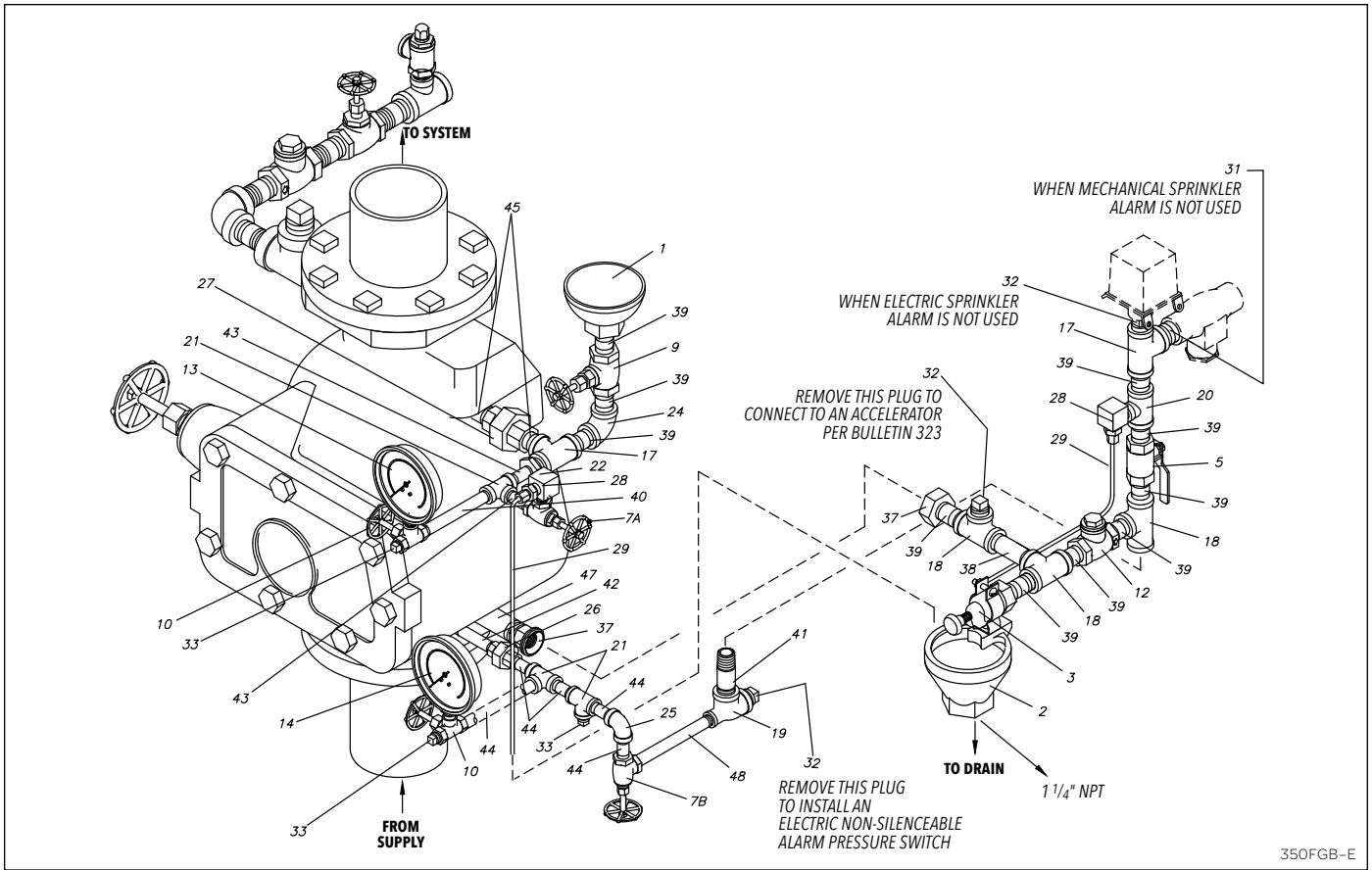

Figure B

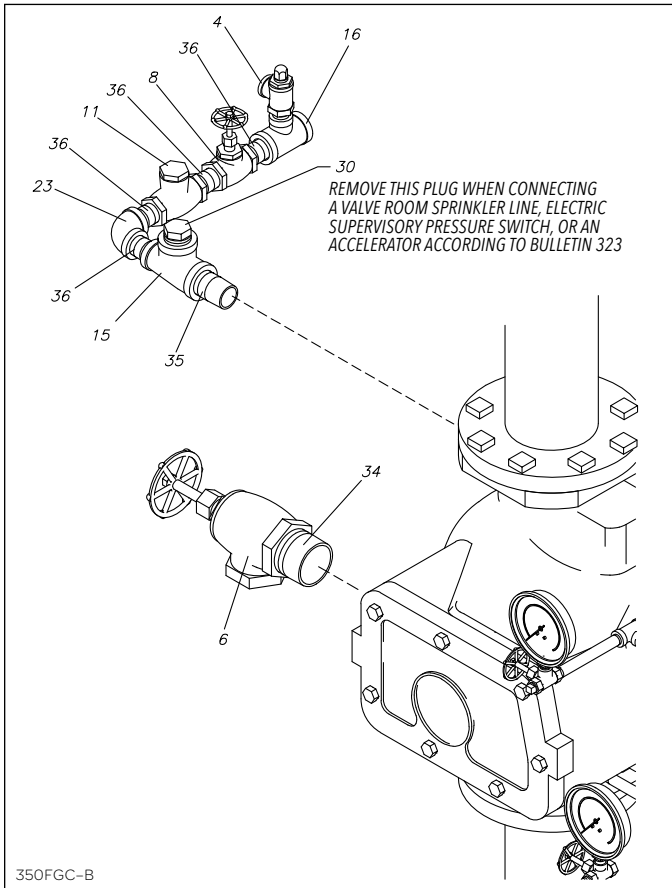

Figure C

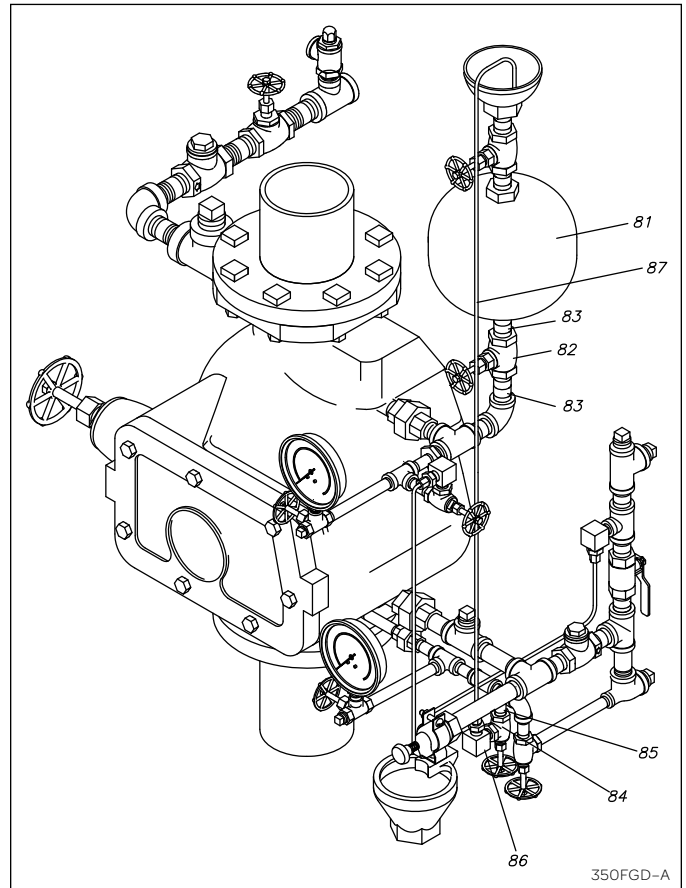

Figure D

**Reliable Model D Dry Pipe Valves—Model D Basic Trim (See Figures B & C)  
(Trim Parts Without Priming Chamber and Fill Line Attachments)  
P/N 6501050100**

Item No.	Part No.	Description	No. Req'd
1	75000050	Priming Cup, 1/2"	1
2	71010471	Drip Cup Assembly	1
3	78653100	Mechanical Ball Drip Valve, 1/2'	1
4	98840190	Relief Valve Bronze, 1/2"	1
5	98840105	Ball Valve, 1/2"	1
6	98840100	Valve, Angle, Bronze, 2"	1
7	98840101	Valve, Angle, Bronze, 1/4"	2
8	98840170	Valve, Globe, Bronze, 3/4"	1
9	98840171	Valve, Globe, Bronze, 1/2"	1
10	98840160	Valve, Gauge, Bronze, Three Way 1/4"	2
11	98840180	Valve, Horiz., Check, Bronze, 3/4"	1
12	98840181	Valve, Horiz., Check, Bronze, 1/2"	1
13	98248000	Gauge, Pressure, Air	1
14	98248001	Gauge, Pressure, Water	1
15	96606602	1" x 3/4" x 1" Galv.	1
16	96606604	3/4" x 3/4" x 1/2" Galv.	1
17	96606603	1/2" x 1/2" x 3/4" Galv.	2
18	98761651	1/2" x 1/2" x 1/2" Galv.	3
19	98761649	1/2" x 1/4" x 1/2" Galv.	1
20	96606607	1/2" x 1/2" x 1/4" Galv.	1
21	96606608	1/4" x 1/4" x 1/4" Galv.	3
22	98048000	Bushing Reducer, 1/2" x 1/4"	1
23	98174402	Elbow, 3/4" Galv.	1
24	98174401	Elbow, 1/2" Galv.	1

Item No.	Part No.	Description	No. Req'd
25	98174404	Elbow, 1/4" Galv.	1
26	98815201	Union, Malleable Iron GJ, 1/4"	1
27	98815202	Union, Malleable Iron GJ, 3/4"	1
28	98164406	Ell. Brass, Male Comp. Type, 3/16" x 1/4"	2
29	98768005	Tubing, Copper, 3/16" x 15" Lg.	2
30	98604405	Plug, 1"	1
31	98614401	Plug, 3/4"	1
32	98604406	Plug, 1/2"	3
33	98614403	Plug, 1/4"	3
34	98543238	Nipple, 2" x Close	1
35	98543222	Nipple, 1" x 3 1/2"	1
36	98543215	Nipple, 3/4" x 1 1/2"	4
37	98815200	Union, 1/2"	1
38	98543209	Nipple, 1/2" x 2"	1
39	98543223	Nipple, 1/2" x 1 1/2"	11
40	98543224	Nipple, 1/4" x 4 1/2"	1
41	98543210	Nipple, 1/2" x 2 1/2"	1
42	98543225	Nipple, 1/4" x 2 1/2"	1
43	98543244	Nipple, 1/4" x 2"	2
44	98543226	Nipple, 1/4" x 1 1/2"	5
45	98543279	Nipple, 3/4" x Close	2
46	-----	-----	-
47	98543207	Nipple, 1/2" x 4"	1
48	98543241	Nipple, 1/4" x 5"	1

**Priming Chamber Attachment (See Fig. D)  
P/N 6501080100**

Item No.	Part No.	Description	No. Req.
81	71010432	Priming Chamber	1
82	98840171	Valve, Globe, Bronze, 1/2"	1
83	98543223	Nipple, Steel, 1/2" x 1 1/2"	2

**Fill Line Attachment (See Fig. D)  
P/N 6501070100**

Item No.	Part No.	Description	No. Req.
84	98840101	Valve, Angle, Bronze, 1/4"	1
85	98543226	Nipple, Steel, 1/4" x 1 1/2"	1
86	98164406	Ell. Brass, Male Comp. Type, 3/16" x 1/4"	1
87	98768001	Tubing, Copper, 3/16" x 42"	1

**Table 2 – Water/Air Pressure**

Water Pressure in Supply Line psi (bar)	Air Pressure to be Pumped into System psi (bar)		Water Pressure in Supply Line psi (bar)	Air Pressure to be Pumped into System psi (bar)	
	Not less than	Not more than		Not less than	Not more than
20 (1.38)	10 (0.68)	20 (1.37)	125 (8.62)	30 (2.06)	40 (2.75)
50 (3.44)	15 (1.03)	25 (1.72)	150 (10.34)	35 (2.41)	45 (3.10)
75 (5.17)	20 (1.37)	30 (2.06)	175 (12.06)	40 (2.75)	50 (3.44)
100 (6.89)	25 (1.72)	35 (2.41)			

**Note:** 4" (100 mm) and 6" (150 mm) Model D Dry Pipe Valves are identical in general design and operation. Maximum water pressure to which the system is liable to be subjected should be taken instead of normal pressure. Fire pumps usually provide pressure in excess of 125 psi (8.62 bar).

**Maintenance**

Dry pipe systems, as a minimum, shall be tested and maintained in accordance with NFPA 25, which provides minimum inspection, testing and maintenance requirements. These requirements include:

- Quarterly main drain flow test.
- Quarterly water flow and low air alarm test.
- Draining of all low point drains as frequently as necessary.
- Annual dry pipe valve trip test, inspection, cleaning, parts renewal as required and valve reset.

## Resetting the Model D Dry Pipe Valve

Figures B, C and E show the trim and valve parts in their normal positions.

1. Close valve controlling water supply to dry pipe valve.
2. Open Main Drain Valve (6), Fig C and drain system.
3. Open all drain valves (remove plugs) and open vents at low points throughout the system, closing them when flow of water has stopped.
4. Push in plunger of Ball Drip Valve (3), Fig. B, to force ball from its seat.
5. Release Cover (3) and raise Clapper Assembly (5), Fig. E, to wide open position by lifting under the rubber facing. Thoroughly clean air and water seats in making certain that they are free from scale, dirt, lint, etc. Inspect and clean or replace rubber facing. Never apply grease, compound, shellac, or any oily substances to seats or rubber facing.  
**Note:** If replacement is necessary, see parts removal.
6. Release Lever Latch by holding clapper slightly above the top latch stop in the body. Push the front tip to the latch down and hold the latch in this tipped position. Lower the clapper onto the seat.
7. Center the locating diameter of the Clapper Rubber Facing (6), around the water seat. The Clapper Assembly (5) should sit flat and with a minimum of movement when the seating is correct.
8. Replace Gasket (4) and Cover (3) and uniformly tighten Cover Bolts (2).
9. Open Valve (9), Fig. B. Fill body of dry pipe valve by pouring water through Priming Cup (1) until water flows into Drip Cup (2) from open Valve (7A), indicating that priming water is at the proper level. Close Valves (9) and (7A). If priming water continues to flow out of the ball drip valve, this means that the rubber facing is not sealing at the air (outer) seat. To correct this, return to Step "5", remove the cover and re-inspect the rubber facing. Replace the facing if required. If the facing appears acceptable, it may be deformed. Pull the outer edge of the rubber down, away from the clapper, so that the rubber contacts the air seat when the clapper is reset.

**Note:** When Dry Pipe Valve is equipped with Priming Chamber Attachment (Fig. D), follow same procedure, but open and close Valves (9) and (82).

10. Open Valve (8) and admit a few pounds of air pressure into the sprinkler system. Close Valve (8).  
Open separately all drain valves (see Step "3") to force any water from low points of the system. Close these valves when dry air appears and replace plugs in valve outlets.
11. Open Valve (8) Fig. C and admit sufficient air into the sprinkler system to hold the dry pipe valve closed against the water supply pressure in accordance with Table 2, Water-Air Pressure. The level of air pressure is adjusted by removing the cap nut on the top of the Relief Valve (4) and turning the now exposed, slotted adjusting screw clockwise to increase pressure or counterclockwise to reduce it. Replace the cap nut and close Valve (8) after the correct air pressure setting has been made according to NFPA 13. Observe if water leaks through Ball Drip Valve (3) into Drip Cup (2). If no leak

occurs, the air seat is tight.

**Note:** If an Automatic Air Pressure Maintenance Device is used, Valve (8) should be left open. See Bulletin 251 for information on this device.

12. Open slightly the valve controlling the water supply to the dry pipe valve, closing Main Drain Valve (6) when water flows. Observe if water leaks through Ball Drip Valve (3) into Drip Cup (2). If no leak occurs, the air and water seats are tight. Open slowly, but fully, the valve controlling water supply to the dry pipe valve and seal in the OPEN position.

## Tests

To test the operation of the dry pipe valve and its alarm equipment, open the inspectors test connection which should cause the mechanical and electric alarms to sound. This test connection is usually located on the end or top line of the system and is equivalent to the operation of one sprinkler. The main control valve must be completely open to allow sufficient flow for the clapper to latch open. Following this test, the system must be drained and the dry pipe valve reset.

To test the operation of the alarm equipment only, without operating the dry pipe valve, open Valve (7B), Figure B. Should the mechanical sprinkler alarm fails to operate, inspect Valve (25) for complete opening and the stainer for clogging.

## Parts Removal

Refer to Figure E.

To remove the Clapper Assembly (5) and the Seat (9), proceed as follows:

1. Clapper Assembly: With the cover removed, the Hinge Pin (12) can be slipped out of its bushings. Prior to this operation, a piece of heavy cardboard or rubber should be placed on the Seat (9) to protect its sealing surfaces. Put the Clapper Assembly (5) on the upper latch stop and push clapper to left so that the latch moves to the downward position. Then rotate the clapper until the bearing legs are at the front of the valve. The clapper can then be removed through the cover opening.

**Note:** If replacement of the rubber facing is required do not over tighten clamping ring bolts. Tighten to 30 in-lb (3.39 N-m). If a torque wrench is not available, tighten bolts finger tight and then an additional 1/8 of a turn only.

2. Seat: With the clapper removed, the seat can be easily unscrewed from the body with the use of the Reliable Model D Dry Valve Seat Wrench [P/N 6881340000 for the 4" (100 mm) size; P/N 6881360000 for the 6" (150 mm) size]. Be careful not to damage the seat during this operation. Prior to replacing the seat, the threads on the body and the seat should be cleaned and lubricated and new lubricated "O"-rings (10) and (11) should be used. White petroleum jelly is an effective lubricant.

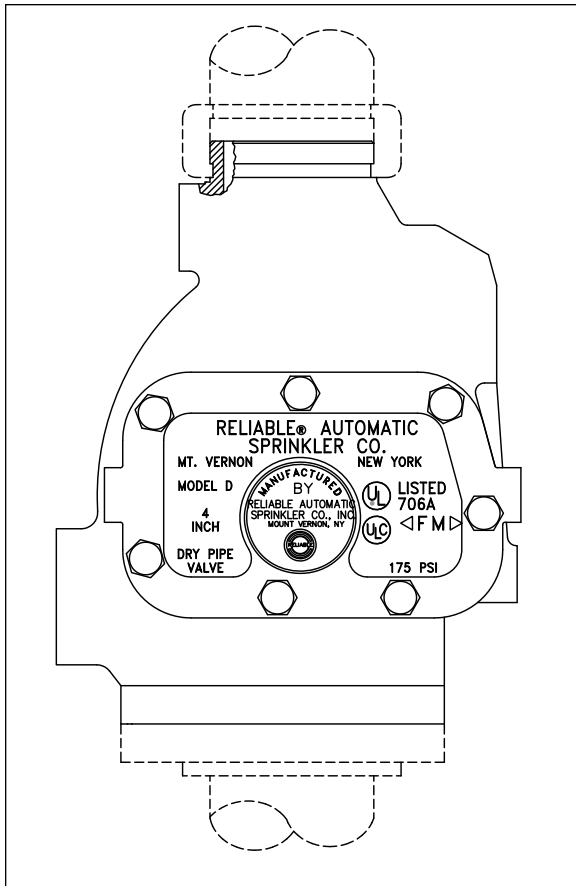

Flanged Inlet and Grooved Outlet

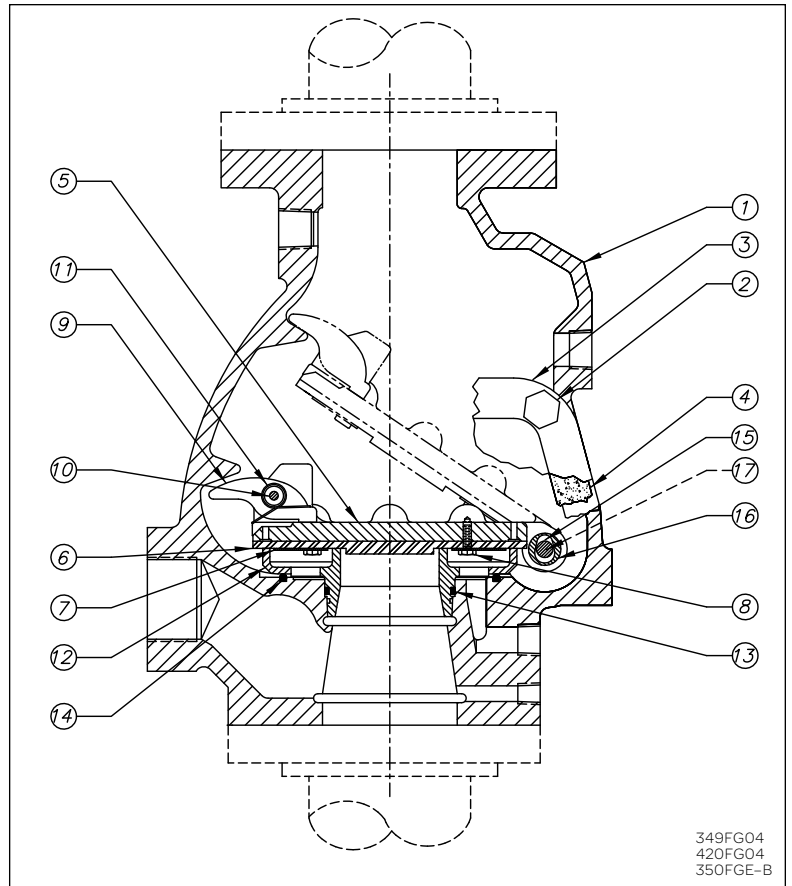

Flanged Inlet and Outlet

349FG04  
420FG04  
350FGE-B

Figure E

Item No.	Part No.	Part No.	Description	No. Required	
	4" Size	6" Size		4" Size	6" Size
1	91006225	91006227	Body Flanged Flanged and Grooved Metric	1	1
	91006214	91006216			
	91006222 (100 mm)	91006223 (150 mm)			
2	91106124	91106126	Cover Bolts	7	8
3	92116224	92116226	Cover	1	1
4	93706224	93706226	Cover Gasket	1	1
5	71010423	71010623	Clapper and Latch Assembly	1	1
6	93406224	93406226	Clapper Rubber Facing	1	1
7	95306224	95306226	Clamping Ring	1	1
8	95606224	95606224	Clamping Ring Screws	8	8
9	96016224	96016226	Seat	1	1
10	95446224	95446226	Seat "O" Ring	1	1
11	95436224	95436226	Body "O" Ring	1	1
12	95006224	95006226	Hinge Pin	1	1
13	98614402	98614402	1/2" Pipe Plug	1	1

Contact the installing contractor or Reliable if any difficulties are experienced. Should replacement parts be needed, use only Reliable manufactured parts. When ordering, specify part number, name, size, model and serial number of the unit.

# Reliable... For Complete Protection

Reliable offers a wide selection of sprinkler components. Following are some of the many precision-made Reliable products that guard life and property from fire around the clock.

- Automatic sprinklers
- Flush automatic sprinklers
- Recessed automatic sprinklers
- Concealed automatic sprinklers
- Adjustable automatic sprinklers
- Dry automatic sprinklers
- Intermediate level sprinklers
- Open sprinklers
- Spray nozzles
- Alarm valves
- Retarding chambers
- Dry pipe valves
- Accelerators for dry pipe valves
- Mechanical sprinkler alarms
- Electrical sprinkler alarm switches
- Water flow detectors
- Deluge valves
- Detector check valves
- Check valves
- Electrical system
- Sprinkler emergency cabinets
- Sprinkler wrenches
- Sprinkler escutcheons and guards
- Inspectors test connections
- Sight drains
- Ball drips and drum drips
- Control valve seals
- Air maintenance devices
- Air compressors
- Pressure gauges
- Identification signs
- Fire department connection

---

The equipment presented in this bulletin is to be installed in accordance with the latest published Standards of the National Fire Protection Association, Factory Mutual Research Corporation, or other similar organizations and also with the provisions of governmental codes or ordinances whenever applicable. Products manufactured and distributed by Reliable have been protecting life and property for over 90 years, and are installed and serviced by the most highly qualified and reputable sprinkler contractors located throughout the United States, Canada and foreign countries.

---

Manufactured by

**Reliable**<sup>®</sup>

**The Reliable Automatic Sprinkler Co., Inc.**

(800) 431-1588

(800) 848-6051

(914) 829-2042

[www.reliablesprinkler.com](http://www.reliablesprinkler.com)

Sales Offices

Sales Fax

Corporate Offices

Internet Address



Recycled  
Paper

Revision lines indicate updated or new data.

EG. Printed in U.S.A. 03/16

P/N 9999970044